



ISSN: 0976-3376

Available Online at <http://www.journalajst.com>

ASIAN JOURNAL OF
SCIENCE AND TECHNOLOGY

Asian Journal of Science and Technology
Vol. 12, Issue, 10, pp. 11849-11855, October, 2021

RESEARCH ARTICLE

INVESTIGATION OF WHEEL LOAD DISTRIBUTION ON RAILWAY FASTENING SYSTEM UNDER DIFFERENT SUPPORTS CONDITIONS

Ingabire Marie Ange*, Abrham Gebre and Ntakiyemungu Mathieu

African Railway Center of Excellence, Addis Ababa Institute of Technology, AAU

ARTICLE INFO

Article History:

Received 24th July, 2021
Received in revised form
24th August, 2021
Accepted 21st September, 2021
Published online 30th October, 2021

Key words:

Load distribution, Support Conditions,
Fastening Systems,
Rail Pad, ANSYS,
Finite Element.

ABSTRACT

Due to a limited understanding of the complex loading conditions which affects the concrete sleeper and fastening components this led to a design process based primarily on practical experience and previous techniques, which fails to include key variables that relate to actual field loading conditions. Thus, missing one or more fastening components can occur in the field under sustained increase demands. Up to now, the performance of concrete sleeper fastening track with missing rail pad at one or more sleepers under different axle wheel loads has not been thoroughly investigated. In this paper, the effect of the different axle wheel loads on concrete sleeper fastening systems under missing rail pad at one or more sleepers was investigated. Five concrete sleeper fastening systems parts were modelled using ANSYS. Missing rail pad at one or more sleepers conditions were simulated and compared with fastening systems with no missing components. It has been revealed that, when rail pad is missing at one or more sleeper the deformation and stress of other components where missing components are located increase more than the full fastened. It has also shown that when axle load increases, the deformation and stress increase at a low rate. The results from this study will help to improve the understanding of wheel load effect on concrete sleeper fastening system under missing rail pad and can be used in future fastening systems design and field maintenance practices.

Citation: Ingabire Marie Ange, Abrham Gebre and Ntakiyemungu Mathieu, 2021. "Investigation of wheel load distribution on railway fastening system under different supports conditions", *Asian Journal of Science and Technology*, 12, (10), 11849-11855.

Copyright © 2021, Ingabire Marie Ange et al. This is an open access article distributed under the Creative Commons Attribution License, which permits unrestricted use, distribution, and reproduction in any medium, provided the original work is properly cited.

INTRODUCTION

The improvement of railway structure for safe and economic train transportation requires the track to serve as stable guideway with appropriate vertical and horizontal alignment, to attain this role each component of the railway system must perform its specific function satisfactorily in the response to the traffic load, train speed and environmental factors imposed on the system (Ir. J. van 't Zand and Ing. J. Moraal, 1998). A sustained increase in heavy axle loads and cumulative freight tonnages, as well as increased interest in high-speed passenger rail development, has placed an increasing demand on railway infrastructure and its components (P.J. Gräbe and D. Jacobs, 2016). Therefore, one of the most critical areas of the infrastructure which need more research and analysis is the concrete sleeper and elastic fastening system used in heavy haul (P.J. Gräbe and D. Jacobs, 2016) because there is a limited understanding of the complex loading conditions (for example load distribution through each concrete sleeper fastening system) affecting the concrete sleeper and elastic

fastening system components led to a design process based primarily on practical experience and previous techniques, which fails to include key variables that relate to actual field loading conditions (Vaidas Ramūnas *et al*, 2016) and also, due to increasingly in demands of heavy-haul freight operations and high-speed passenger may lead to track components failure such fatigue, cracking of sleeper, rail seat deformation etc.(Vaidas Ramūnas *et al*, 2016), and according to the researches done the influences of train speed and axle loads on life cycle of rail fastenings proposed that increases in axle loads cause substantial increases in the fastening plastic deformations (E. Kassa, 2018) and can also cause missing fastening component(s) on one or more sleepers in the field. Heavy Axle load and high-speed train can also cause the loss of material beneath the rail which can lead to wide gauge, can't deficiency, reduced clamping force of the fastening system, and an increased risk of rail rollover (Brevet G. J. Holder *et al*, 2017). Therefore, the enhancement of the performance, efficiency, and durability of current concrete crosstie fastenings under variety of loading conditions and sleeper must be optimize so that sleeper and fastening systems will be capable of performing well under a wide range of service conditions (J. Grassé, 2016). To better understand the performance of the fastening system under different support such as missing rail pad at one or more sleepers, a FEA was

*Corresponding author: Ingabire Marie Ange,
African Railway Center of Excellence, Addis Ababa Institute of
Technology, AAU.

used to investigate the magnitude and distribution of the different vertical wheel load and deformation through the track superstructure when one or more fastening components are missing. It is expected that the information from this paper will help the rail industry in improving fastening system design, performance, and maintenance for heavy-haul freight railroad applications as well as to gain a better understanding of the effect of different vertical wheel loads distribution under different supports when fastening component(s) are removed.

METHODOLOGY

Load distribution through sleepers: The fastening system is a vital track component which plays an important role in transferring loads between the rail and the sleeper(Zijian Zhang *et al*, 2016). If the fastening system does not operate efficiently, the rail may absorb more force than desirable and longitudinal movement of the rail through the fastening system may occur. This has an effect on the stress-free temperature which could allow it to vary substantially; making it problematic for track maintenance personnel to monitor the rail stresses(Brandon Van Dyk *et al*, 2015). In this research a point load was applied on rail section the same way as indicated in figure.1.The Figure 1 below shows how point load was distributed among five concrete sleepers.

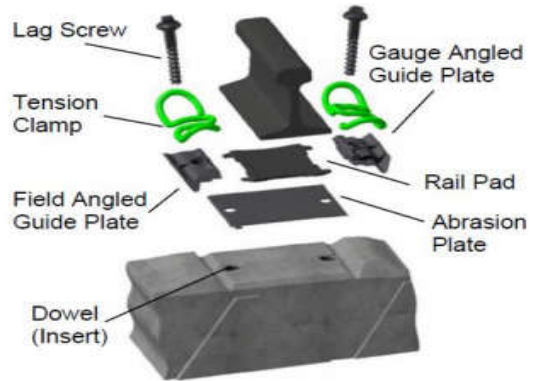

Figure 2: Vossloh Fastening Systems W 40 HH AP fastening system(Van Dyk and Brandon, 2014)

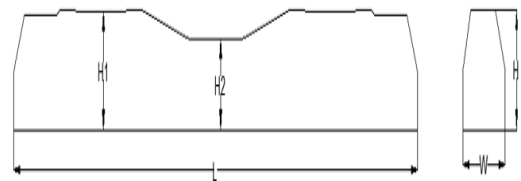

Figure 3. Dimensions of concrete sleeper

Table 1. Components dimensions (USA HHS 36/6 RAIL.ONE GmbH 2014)

Parameters	Unit
Concrete grade	C 50/60
Sleeper length (L)	2600 mm
Sleeper width (W)	272 mm
Sleeper height (H)	252 mm
Height of center of rail base (h_1)	248 mm
Height of sleeper center (h_2)	190 mm
Rail dimensions	UIC60
Rail pad dimensions	150x160x6 mm
Abrasion plate dimensions	150x170x7 mm
Insulator dimensions	160x45x26 mm
Rail clip diameter	16mm
Bolt diameter	24mm

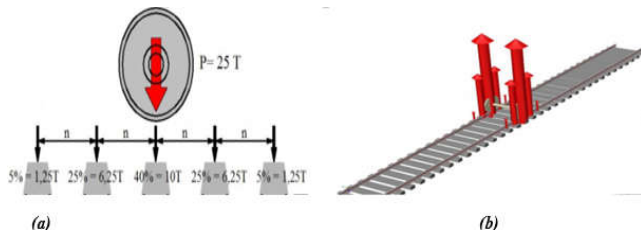

Figure 1. (a). Load distribution through sleepers in case of concentrated load, where P is the Axle load in tones, (T); n is the distance between the axles of sleepers (FIB,2006)and (b) Wheel load distribution through five sleepers (J. Zeman, 2010)

MATERIALS

The type of fastening used is Vossloh Fastening Systems W 40 HH AP fastening system (Van Dyk and Brandon, 2014). Concrete sleeper equipped with Skl-style fastening systems were used as described in figure 2. The Skl-style fastening system consist of five major components which are the tension clips, guide plates, lag screw/dowel, and rail pad that all ensure their performance as described in the Figure 2. Therefore, the tension clips are designed to have high fatigue strength, which allows them to maintain their clamping ability over extended periods of time. The lag screw (bolt and nuts) and dowel combination hold the tension clamp to the sleeper and help to decrease the transverse stress on the concrete sleeper (Hanna and Amir, 1975). The rail pad is designed to provide appropriate resilience and also to withstand the high pressures that are associated with heavy haul trains. The Table.1 describes the component dimensions and figure 2, Figure 3, Figure 4 show the rail and concrete sleeper fastening systems to be used in the 3D FE modelling. The material properties of concrete and fasteners used as input values in finite element analysis are given in the Table 2.

Concrete sleeper fastening system modeling: In order to investigate the responses of the fastening system under different loading scenarios and missing rail pad at one or more

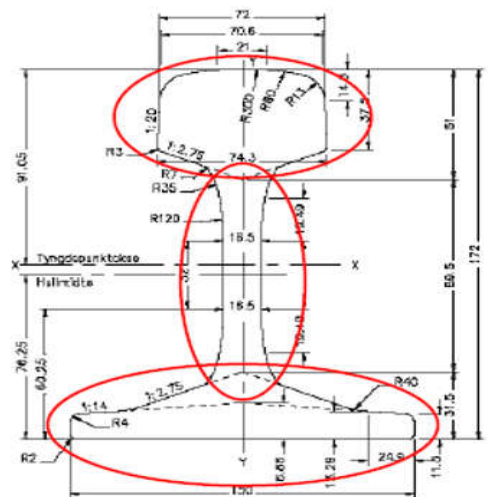

Figure 4. UIC60 Rail profile (J. Grassé, 2016).

sleepers, finite element model for concrete sleeper fastening system is established using Finite Element package – ANSYS 18.1, which is a numerical tool used to model and simulate the mechanics behaviour and response of concrete sleeper fastening system. In this study, each track structure component was modelled separately and assembled together as a three-dimensional solid element, SOLID 65.

Table 2. The Material properties of the model (J.Sadeghi, 2008)

Component	Material property of each component					
	Density (Kg/m ³)	Young's modulus E (MPa)	Poisson's ratio	Yield Strength (MPa)	Ultimate Strength (MPa)	Ultimate Strain
Ballast	27609.9	1.3×10^2	0.4	N/A	N/A	N/A
Clip	7830.17	1.59×10^5	0.29	1.26×10^3	1.39×10^3	0.05
Crosstie	2300.83	3.00×10^4	0.2	2.43×10^1	4.83×10^1	0.00143
Field Side	1137.53	3.03×10^3	0.35	8.27×10^1		
Insulator	7830.17	1.69×10^5	0.3	3.10×10^2	4.48×10^2	0.01
Gauge side Insulator	1137.53	3.03×10^3	0.35	8.27×10^1	N/A	N/A
Rail	8006.87	2.07×10^5	0.3	N/A	N/A	N/A
Rail Pad	1016.04	5.17×10^1	0.394	3.59×10^1	N/A	N/A

Then, fastening components which are clip, guide plate, rail pad and bolt and a half concrete sleeper were modelled separately and assembled together to form a set of five concrete sleeper fastening systems and sleeper spacing was 0.6m centre to centre. Five concrete sleepers were chosen to be used in analysis because concentrated load is usually distributed on five sleepers (FIB,2006; J. Grassé, 2016). Then, this set of five concrete sleeper fastening systems were assembled with rail and ballast support of 0.3m thick. In the working environment, the vertical wheel load is applied at 100mm² area on the top of the railhead at the third sleeper. The non-linear material properties inputs have been given in the previous sections. The concrete sleeper fastening system model was modelled and analyzed in ANSYS 18.1 as shown in the figure 5 below:

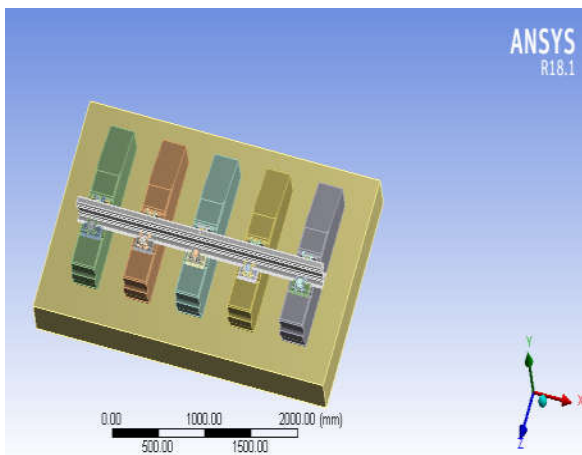

Figure 5. Five concrete sleeper fastening system with supporting ballast 3D modeling

Meshing

The model was meshed as shown in figure 6 below. In this model, the geometries of all the components were simplified. All track components were modelled using the mesh of four-node tetrahedron for (rail, and concrete sleeper fastening systems) and eight-node hexahedron for (ballast) three-dimensional deformable solids. In all cases, the contact was defined as a bonded contact because the capacity of computer and the general maximum size of the elements of concrete sleeper fastening systems (five sleeper with their fastening system) was 20mm and size of the elements of rail and supporting ballast was 40mm. And also, the fixed support was applied under ballast as boundary condition. Therefore, the final mesh consists of the following nodes and elements:

- 971,625 nodes and 651,502 elements for fully fastened concrete
- 862,465 nodes and 525,905 elements for missing center rail pad
- 861,215 nodes and 525,746 elements for missing rail pad on 2nd and 4th sleeper

So that the models will yield accurate results with acceptable computing time.

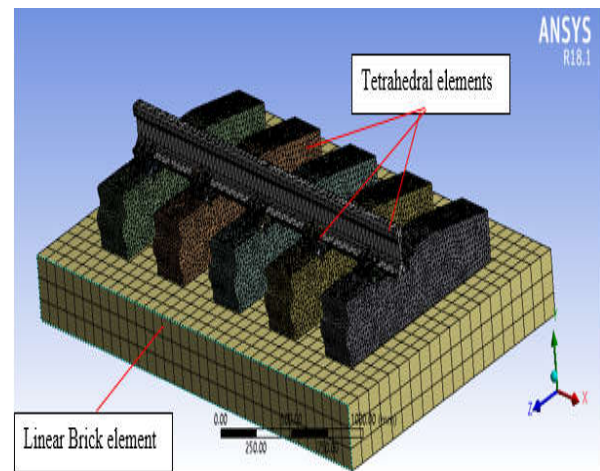

Figure 6. Meshed concrete sleeper fastening system model

RESULTS AND DISCUSSION

On field, due to the increase of tonnage during service life, it is possible for some concrete sleeper fastening components to experience failure caused by fatigue, fracture, or crushing which can lead to missing some fastening components on the track superstructure. Thus, the performance of the concrete sleeper fastening systems under missing rail pad at center or second & fourth sleepers conditions is worth being investigated. A static structural analysis was used to determine the stresses and deformation of each concrete sleeper fastening component which was performed by using ANSYS 18.1, different vertical wheel loads which are 25t, 30t and 35t at the middle sleeper were separately applied at the third sleeper. Missing rail pad at one or more sleepers conditions were simulated and compared with fastening systems with no missing components. The Figures below show the maximum stress resisted by each concrete sleeper fastening components and also show the maximum total deformation of each concrete sleeper fastening component under missing rail pad at one or more sleepers and on that same graph, the averaged fully fastened FE results are also provided for comparison, all on the y-axis and with its corresponding sleeper on the x-axis.

- The incremental percentage of stress resisted by each concrete sleeper fastening component (sleeper, clips, rail pad, guide plates and bolts) was calculated by dividing the subtraction of maximum stress of fully fastened and non-ideal condition by the maximum stress of fully fastened condition.
- The incremental percentage of deformation of concrete sleeper fastening component (sleeper, clips, rail pad, guide plates and bolts) was calculated by dividing the subtraction of maximum total deformation of fully fastened and non-ideal condition by the maximum total deformation of fully fastened condition.

Stress resisted by sleeper

- As you increase the axle load when all five concrete sleeper fastening systems are fully fastened there were no significant incremental in stresses resisted by sleeper. Once the rail pad is removed at center sleeper and at 2nd & 4th sleepers, the stresses acting on sleeper increase more than fully fastened. The stresses were increased in range 23% - 79%.

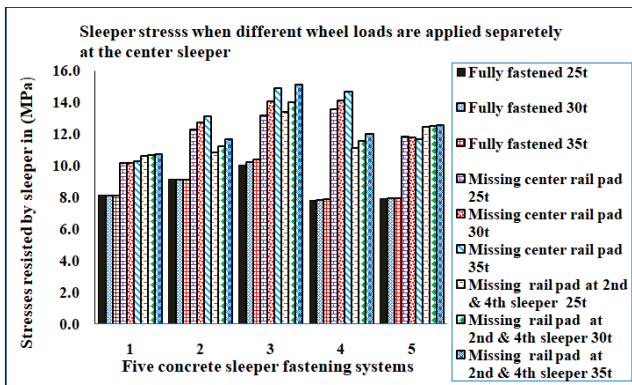

Figure 6. Sleeper stresses when different vertical wheel loads are applied under different support conditions

Stresses resisted by Clips: When all five concrete sleeper fastening systems are fully fastened there were incremental in stresses resisted by clips of the third sleeper as axle load was increasing. Once the rail pad is removed at center sleeper or at 2nd & 4th sleepers, the stresses acting on clips of each sleeper increase (10.2% - 75.1%) more than fully fastened. Much stresses were concentrated on three middle sleepers (2nd, 3rd and 4th sleeper).

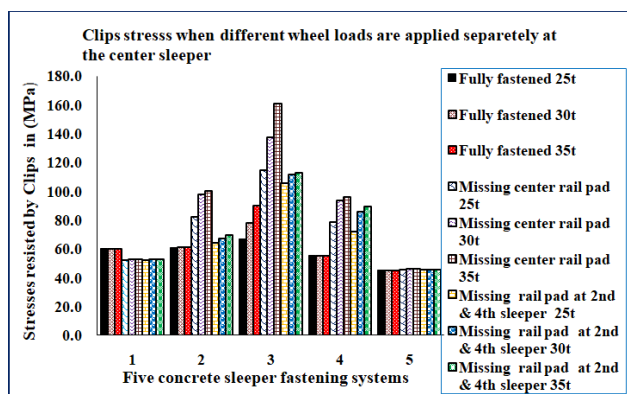

Figure 7. Clips stresses when different vertical wheel loads are applied under different support conditions

Stresses resisted by Rail Pad

When all five concrete sleeper fastening systems are fully fastened there were incremental in stresses resisted by rail pad of each sleeper. Once the rail pad is removed at center sleeper, the stresses acting on rail pad of each sleeper increases more than fully fastened. Thus, the percent stress resisted by rail pad on the 1st, 2nd, 4th and 5th sleeper, all increased to 163%, 204%, 213%, and 199.6% respectively. And also, once the rail pad is removed at 2nd and 4th sleepers. Therefore, the percent stress resisted by remaining rail pad means rail pad on 1st, 3rd and 5th sleeper all increased to 224.4%, 77% and 267.5% respectively.

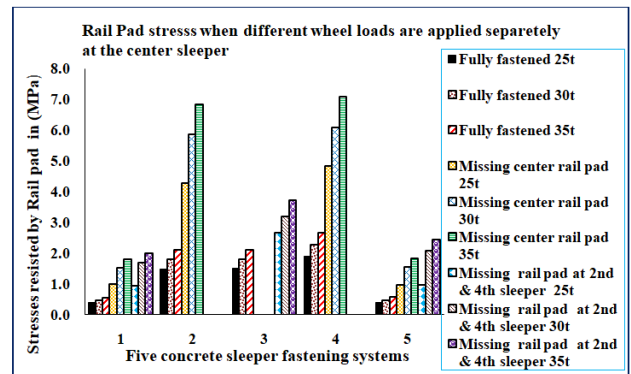

Figure 9. Rail Pad stresses when different vertical wheel loads are applied under different support conditions

Stresses resisted by guide plates: When all five concrete sleeper fastening systems are fully fastened there were incremental in stresses resisted by guide plates especially guide plates of 2nd, 3rd, and 4th sleeper. Once the center rail pad is removed, the stresses acting on guide plates of each sleeper increase more than fully fastened. Thus, the percent stress resisted by guide plates on the 1st, 2nd, 3rd, 4th and 5th sleeper, all increased to 41%, 126.8%, 263%, 105.4% and 51% respectively. Once the rail pad is removed at 2nd and 4th sleepers, the stresses acting on guide plates of each sleeper increase more than fully fastened. Therefore, the percent stress resisted by guide plates on 1st, 2nd, 3rd, 4th and 5th sleeper all increased to 48.2%, 221.3%, 57.5%, 202.7% and 57.6% respectively.

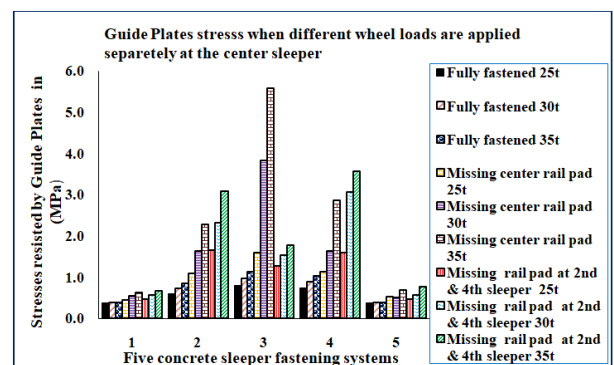

Figure 10. Guide plates stresses when different vertical wheel loads are applied under different support conditions

Stresses resisted by bolts: When all five concrete sleeper fastening systems are fully fastened there were incremental in stresses resisted by bolts of all five sleepers.

Once the rail pad is removed at center sleeper or at 2nd & 4th sleepers, the stresses acting on bolts of each sleeper increase (11.3 % - 46.6%) more than fully fastened.

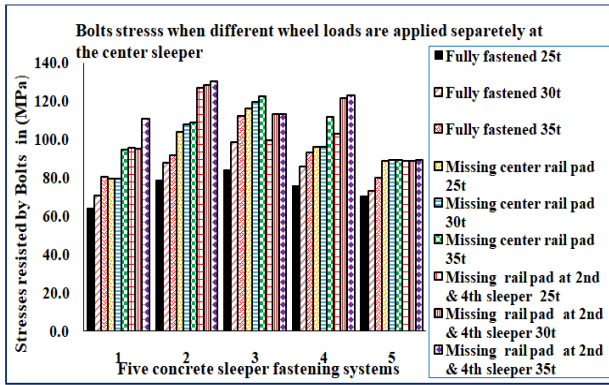

Figure 11. Bolts stresses when different vertical wheel loads are applied under different support conditions

Sleeper deformation: When all five concrete sleeper fastening systems are fully fastened, the deformation of sleeper increased as the axle load was increasing and much deformation were concentrated on third sleeper. Rail pad help to distribute load to the large surface and also help to eliminate load concentration. Once the centre rail pad is removed as compared to fully fastened, it was observed that the deformation of third sleeper reduced 72.1 % significantly this showed that much deformation were transferred to the other concrete sleeper fastening systems especially guide plates and clips of the third sleeper and other deformation rest concentrated on the adjacent sleeper (2nd and 4th sleeper) which increased to 86% and 90.3% respectively. Once the rail pad is removed at the 2nd and 4th sleepers as compared to fully fastened, the percent deformation of the 2nd and 4th sleeper were decreased to 51.21% and 50.88% respectively, but much deformations were concentrated on the 3rd sleeper which increased to 33.43%. Therefore, once rail pad is removed at any sleeper, there is a decreasing in deformation corresponding to the location of the removal sleeper. This may be due to an unseal gap between the bottom of the rail track and the top of removal sleeper which may allow the rail more freedom to transfer load on the remaining sleepers and also to other concrete sleeper fastening systems. The significant reduction in deformation especially at removal sleeper also due to the lack of its rail pad which helps to absorb the uneven surface contact between rail and support.

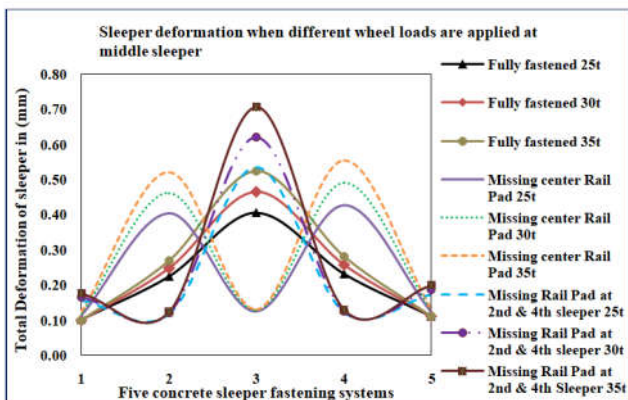

Figure 12. Sleeper deformation when different vertical wheel loads are applied under different support conditions

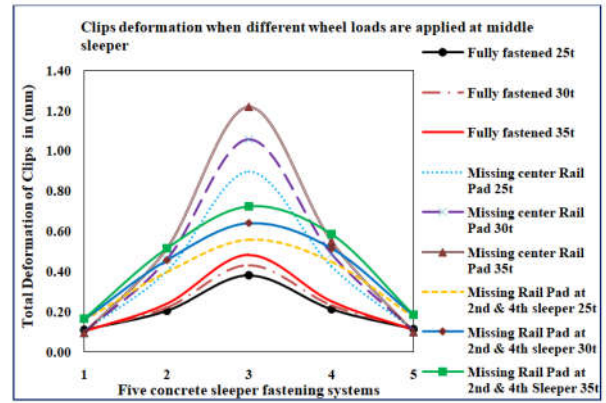

Figure 13. Clips deformation when different vertical wheel loads are applied under different support conditions

Deformation of the Clips: When all five concrete sleeper fastening systems are fully fastened, the deformation of clips increased especially for clips of the third sleeper as the axle load was increasing. Once the centre rail pad is removed as compared to fully fastened, it was observed that clips on the third sleeper are highly deformed which increased to 144.14%, and percent deformation of clips on two adjacent sleepers (2nd and 4th sleeper) all increased to 106.46% and 108.63% respectively. Once the rail pad is removed at the 2nd and 4th sleeper, when it was compared with fully fastened, it was observed that clips on the 2nd and 4th sleepers are highly deformed which were increased to 105.76% and 120.71% respectively. And the percent deformation of the 1st, 3rd and 5th sleeper were also increased to 53.7%, 48.29% and 59.1% respectively. Therefore, the significant rise in deformation of clips may also due to the lack of rail pad which helps to distribute load to the large elastic surface and also help to absorb the uneven surface contact between rail and support.

Deformation of the rail pad: When all five concrete sleeper fastening systems are fully, the deformation of rail pad increased especially for rail pad of the third sleeper as the axle load was increasing. Once the centre rail pad is removed, it was observed that rail pad on the second and fourth sleeper are highly deformed which increased to 116.82% and 117.23% respectively than fully fastened. Once the rail pad on the 2nd and 4th sleeper is removed, the deformation of rail pad increases more than fully fastened. It was observed that rail pad on the 3rd was highly deformed which increased to 105.14%.

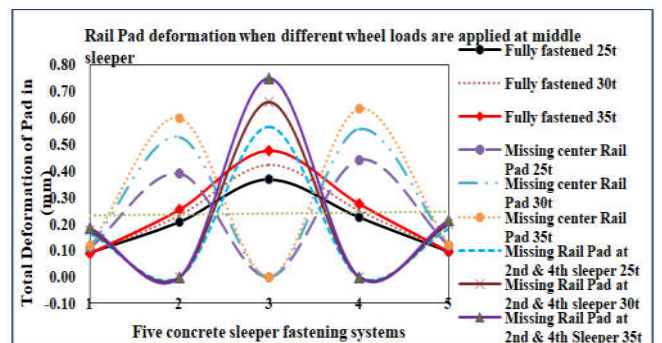

Figure 14. Rail Pad deformation when different vertical wheel loads are applied under different support conditions

Deformation of the guide plates: When all five concrete sleeper fastening systems are fully fastened, the deformation of guide plates increased especially for guide plates of the third sleeper as the axle load was increasing. Once centre rail pad is removed, the deformation of guide plates increases more than fully fastened, it was observed that guide plates on the 2nd, 3rd and 4th sleeper are highly deformed which increased to 89.29%, 142.99% and 91.27% respectively. When Rail Pad is removed at the 2nd and 4th sleeper, the deformation of guide plates increases more than fully fastened. it was observed that guide plates on each sleeper are highly deformed, means the percent deformation of the guide plates on the 1st, 2nd, 3rd, 4th and 5th sleeper was increased to 81.84%, 108.16%, 51.72%, 115.19% and 93.22% respectively.

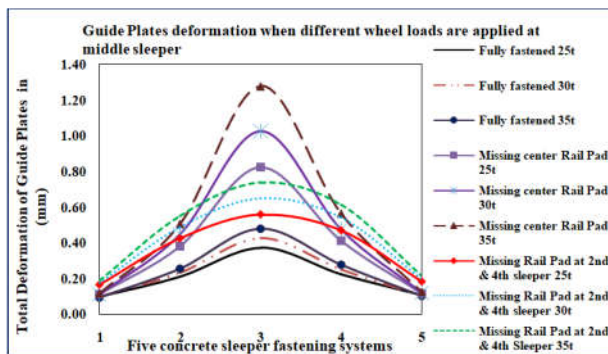

Figure 15. Guide Plates deformation when different vertical wheel loads are applied under different support conditions

Deformation of the bolts: When all five concrete sleeper fastening systems are fully fastened, the deformation of the bolts increased especially for bolts of the third sleeper as the axle load was increasing. When the centre rail pad is removed, the bolts of 2nd and 4th were deformed than fully fastened which increased to 89.79% and 93.23% respectively. But the deformation of the bolts of the third sleeper was decreased to 64.86 %. Once the rail pad on the 2nd and 4th sleeper is removed and when it was compared with fully fastened, it was observed that the percent deformation of the bolts on the 2nd and 4th sleeper was decreased to 20.54% and 37.68 % respectively and other remaining bolts were increased to (44.81% -59.19%).

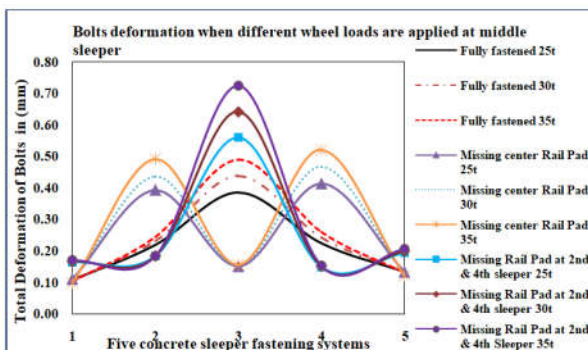

Figure 16. Bolts deformation when different vertical wheel loads are applied under different support conditions

CONCLUSION AND RECOMMENDATION

This study presents a static structural FEA focused on investigation of different vertical axle wheel loads effect on concrete sleeper fastening systems under missing rail pad.

A 3D solid of five concrete sleeper fastening systems parts were modelled by using Solidwork19 and ANSYS18.1 was used for simulation. The following conclusions were drawn from FE results:

- When all five concrete sleepers are fully fastened, the majority of the stresses and deformation are concentrated into three concrete sleeper fastening systems under vertical point load as axle load was increasing.
- Once rail pad is removed at one or more sleepers, the stresses acting on each concrete sleeper fastening components increased more than fully fastened condition. The stresses were mainly transferred into two adjacent sleepers.
- Once rail pad is removed at third sleeper, much deformation was concentrated on clips and guide plates of the third sleeper and others were concentrate to adjacent concrete sleeper fastening systems and also, when the rail pad is missing at 2nd and 4th sleepers much deformations were concentrated on the middle sleeper fastening system.
- This paper focused on static model of concrete sleeper fastening systems under different supports conditions. Therefore, it is recommended to investigate different dynamic loads effect on concrete sleeper fastening systems under these support conditions by varying train speed.

REFERENCES

- Ir. J. van't Zand and Ing. J. Moraal, 1998, "Static and dynamic tests on rail fastening systems," Delft University of Technology, DELFT.
- Gräbe P.J. and D. Jacobs, 2016, "The effects of fastening strength on the variation in stress-free temperature in continuous welded rail," Proc. Inst. Mech. Eng. Part FJ. Rail Rapid Transit, vol. 230, no. 3, pp. 840-851.
- Vaidas Ramūnas, Inesa Gailienė, Alfredas Laurinavičius, 2014, "Crushed rock ballast bed in the railway lines of Lithuania: analysis of the situation and arising problems," in The 9th International Conference "Environmental Engineering", Vilnius, Lithuania.
- Kassa, E. 2018, "Chapter 4. Static Analysis of Track Structures," in Railway Track Engineering, Addis Ababa, Addis Ababa University, Addis Ababa Institute of Technology, pp. 57-128.
- Brevet G. J. Holder, Yu Qian, Marcus S. Dersch & J. Riley Edwards, 2017, "Lateral load performance of concrete sleeper fastening systems under non-ideal conditions," in IHHA 2017, Cape Town.
- Grassé, J. D. Lange, S. Wei, D. Kuchma, 2016, "Field Testing of Concrete Sleepers and Fastener Systems for the Understanding of Mechanistic Behavior," University of Illinois at Urbana-Champaign, Urbana, IL, USA.
- Zijian Zhang, Sihang Wei, Bassem Andrawes, Daniel A. Kuchma & J. Riley, 2016, "Numerical and experimental study on dynamic behaviour of concrete sleeper track caused by wheel flat," International Journal of Rail Transportation, vol. 4, no. 1, pp. 1-19.
- Brandon Van Dyk, Winfried Böstlerling, Nicole Wiethoff, Dr. Michael Harrass and Artur Wroblewski, 2015, "Rail Fastening System Design Considerations to Reduce the

- Stress Within Haul Track Superstructure,” in IHHA2015, Perth, Australia.
- FIB, 2006, “Precast concrete railway track systems,” Int. Fed. Struct. Concr. (fib no. Spring-Digital-Druck.), Stuttgart, Germany.
- Zeman, J. 2010, “Hydraulic Mechanisms of Concrete Tie Rail Seat Deterioration,” University of Illinois, Urbana-Champaign, Urbana, Illinois.
- Van Dyk and Brandon, 2014, “Characterization of the loading environment for shared-use railway superstructure in North America,” Masters Thesis, University of Illinois at Urbana, Illinois.
- Hanna and Amir, 1975, Railway Track Research – Theoretical and Experimental, Skokie, IL: Portland Cement Association.
- Sadeghi, J. 2008. “Experimental evaluation of accuracy of current practices in analysis and design of railway track sleepers,” Canadian Journal of Civil Engineering, vol. 9, no. 35, pp. 881-893.
- Grassé, J. D. Lange, S. Wei, D. Kuchma, 2016, “Field Testing of Concrete Sleepers and Fastener Systems for the Understanding of Mechanistic Behavior,” University of Illinois at Urbana-Champaign, Urbana, IL, USA.
