



ISSN: 0976-3376

Available Online at <http://www.journalajst.com>

ASIAN JOURNAL OF  
SCIENCE AND TECHNOLOGY

Asian Journal of Science and Technology  
Vol. 09, Issue, 03, pp.7737-7739, March, 2018

## RESEARCH ARTICLE

### DESIGN OF TELESCOPIC CASCODE SINGLE STAGE OPERATIONAL TRANSCONDUCTANCE AMPLIFIER

**\*Dara Rama Krishna and Dr. R.V.S. Satyanarayana**

Sri Venkateswara University College of Engineering, Tirupathi, India

#### ARTICLE INFO

##### Article History:

Received 11<sup>th</sup> December, 2017  
Received in revised form  
26<sup>th</sup> January, 2018  
Accepted 14<sup>th</sup> February, 2018  
Published online 30<sup>th</sup> March, 2018

##### Key words:

Common source, common drain, telecommunications, analog filter, a/d converter, switched capacitor filters, cascade, transconductance, low power circuits, low voltage.

*Copyright © 2018, Dara Rama Krishna and Dr. Satyanarayana. This is an open access article distributed under the Creative Commons Attribution License, which permits unrestricted use, distribution, and reproduction in any medium, provided the original work is properly cited.*

#### ABSTRACT

In the recent years there is rapid growth in the CMOS technology, which made analog integrated circuits to dominate today's existing market which provides low cost, and excellent performance of systems. Now-a-days wide band analog signal processing helps to find variety of applications in telecommunications and for the medical electronics. Since we prefer continuous time filtering for the low voltage, low power applications. An analog LPF forms the main building block in all of the systems. The operational transconductance based OTA is selected for the realization of analog filter due to their structural simplicity and monolithic integrability. In this paper a telescopic cascade single stage OTA was designed.

#### INTRODUCTION

The operational transconductance amplifier is a basic building block which is used in many analogue and mixed circuits. Examples are Analog to digital converters and switched capacitor filters which require desired performance different OTA were designed.

#### Different OTA Topologies

##### Single stage OTA

Single stage OTA has less complexity in design when compared to other types of OTA topologies. Due to the low complexity in circuit design, its speed is higher than any other OTA topology. The single stage OTA has less gain due to the output impedance of the single stage OTA is less. But the output impedance of single stage OTA is not a drawback. However, its low output impedance leads to high unity gain bandwidth and speed. Single stage OTA has less power consumption when compared to other types of OTA.

##### Two stage OTA

Two stage OTA has more gain when compared to single stage OTA.

One of the two stages, one stage will provide high gain and other stage provides high voltage swing. This change increases the gain when compare to single stage OTA.

##### Advantages

- Two stage OTA has high voltage swing.
- It has more gain compared to single stage OTA.

##### Disadvantages

- Its frequency response should be compromised.
- Because of two stages, power consumption is high.
- Two stage OTA has poor power supply rejection at high frequencies.

##### Telescopic OTA

The telescopic OTA has low voltage gain due to the fact that it has low output impedance. But the overall gain can be improved by adding active load at output.

##### Advantages

- It provides high speed.
- Its power consumption is low.

##### Disadvantages

- Limited output swing.
- Shorting of input and output is difficult.

**\*Corresponding author: Dara Rama Krishna,**  
Sri Venkateswara University College of Engineering, Tirupathi,  
India.

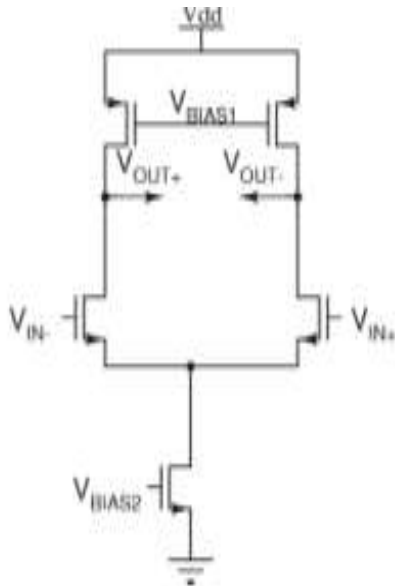

Fig. 1. Single Stage Ota

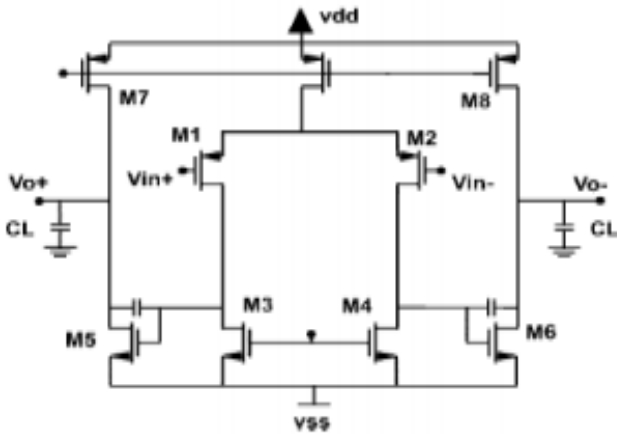

Fig. 2. Two Stage Ota

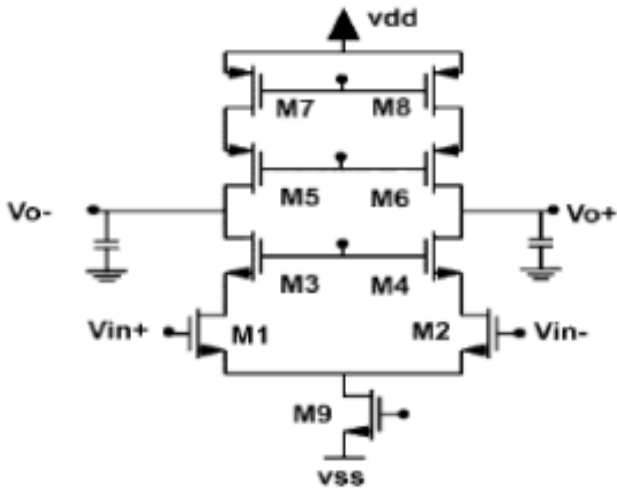

Fig. 3. Telescopic Ota

**Folded Cascode OTA**

Folded cascode OTA is a compromise between two stage amplifier and telescopic cascode amplifier. It allows low supply input voltage, still have a higher output voltage swing. The gain of the folded cascode OTA is lower than the two stage OTA and its speed is also lower than the telescopic cascode.

**Advantages**

- The Folded Cascode OTA has corresponding superior frequency response than the two stage operational amplifiers.
- It has more high frequency power supply rejection ratio.

**Design and Operation**

In this paper, single stage telescopic cascode OTA is designed Microwind package is used to implement the circuit.

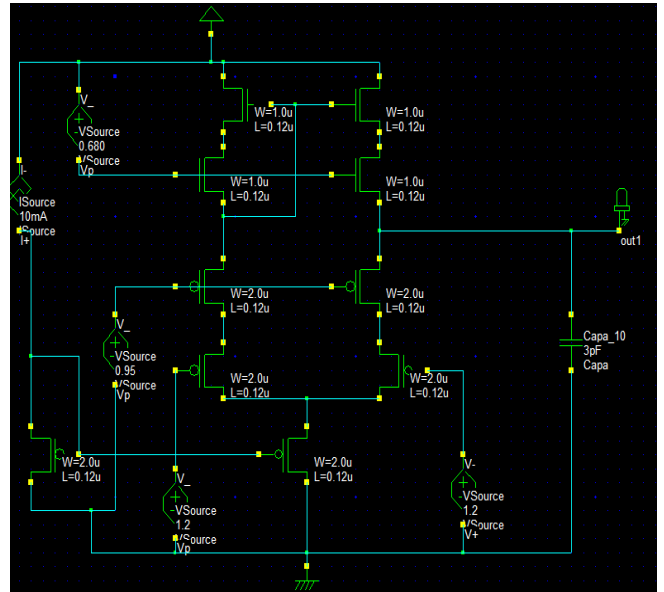

Fig. 5. Telescopic Cascode Single Stage Ota

PMOS and NMOS will be switched on depending on input logic voltages. When  $v_i = \text{logic '0'}$  PMOS will be turned ON and  $v_i = \text{logic '1'}$  NMOS will be turned ON. Single stage telescopic OTA which is designed in this paper has low voltage gain. NMOS will behave as a common source amplifier, PMOS will behave as a common drain amplifier. operation of the circuit is as follows. when input voltage making transition from HIGH level (1.2 volts) to LOW level(0 volts). PMOS transistors are ON and entire PMOS configuration acts like a resistance and provides a path for the output capacitor to charge through ON resistance of PMOS transistor to get the output voltage 1.22 volts .when the input voltage is switching from LOW voltage (0 volts) to HIGH voltage (1.2 volts). NMOS transistors configuration will be ON. Now there is a path for the output capacitor to discharge through on resistance of NMOS transistor configuration to get the output voltage as (0.8volts).

**RESULTS AND CONCLUSION**

**Output voltage and input voltage with time**

**DC Gain**

The DC gain obtained here is a unity dc gain. The dc Gain is plotted in figure 7. In the above Figure,  $V_{out}$  and  $V_{in}$  are in volts.

Input voltage=1.2 volts.

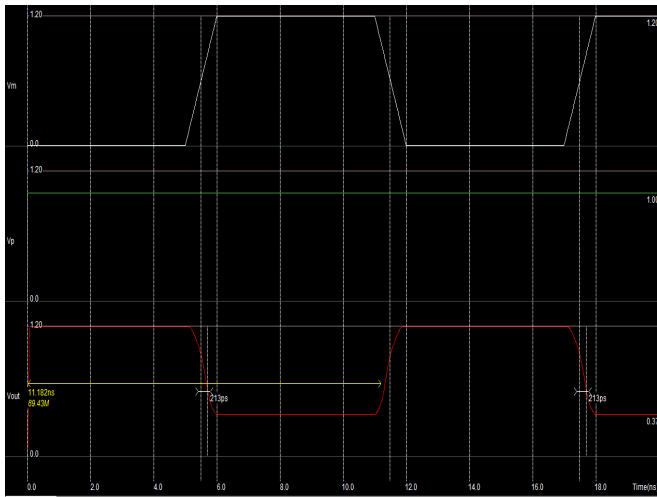

Fig. 6. Output Voltage with time

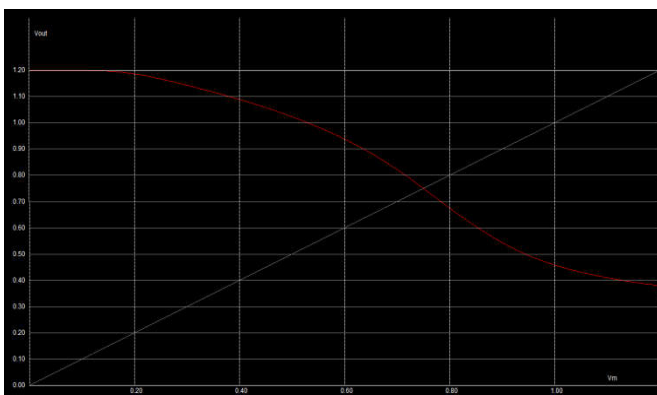

Fig. 7. Dc Voltage Gain

output voltage obtained is 1.22volts  
 gain in dB =  $\log(1.22/1.2) = 0.14$  dB.

**Gain Bandwidth Product**

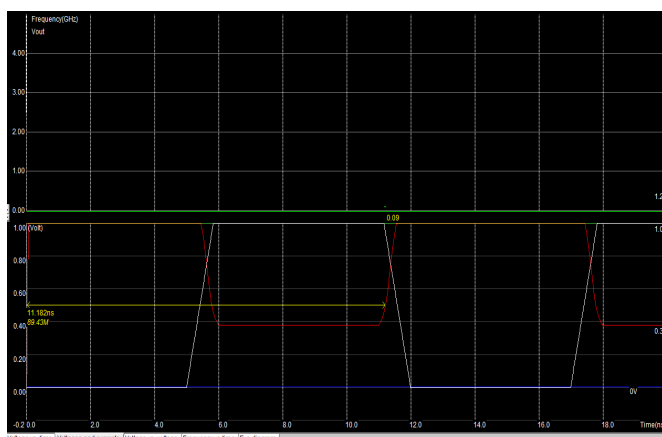

Fig. 8. Gain Bandwidth Product

In the above figure ,obtained gain bandwidth product is = 89.4 MHZ

**RMS Current**

Rms current must be maximum .because it indicates how much output voltage delivered to load. if maximum current is leaked , then the output voltage will be maximum.

$$I_{rms} = 0.452 \text{ ma.}$$

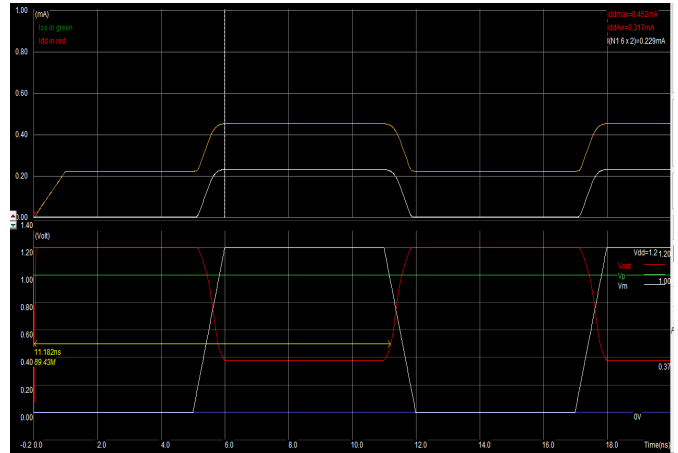

Fig. 9. Rms Current

**Figure Ofmerit**

Figure of merit is given by,  $FOM = (GBW * C) / (I_{rms})$   
 GBW = 89.43 MHZ, C = 6 Pf,  $I_{rms} = 0.452$ ma  
 So, FOM = 1190

cascode OTA has low voltage gain .this is due to less output impedance. so, we can increase the output impedance by placing active load thereby increasing voltage gain . However telescopic cascode single stage OTA has more speed when compared to other type of OTA. If gain is the major desired parameter we can go to other types of OTA for example common mode feedback differential OTA.

**REFERENCES**

Bazarjani, S. and Snelgrove, M. 1997. “A 40 MHz IF Fourthorder Double-Sampled SC Bandpass Sigma-Delta Modulator”, Proceedings of IEEE International Symp. On Circuits and Systems,  
 Franco maloberti,”ANALOG DESIGN FOR CMOS VLSI SYSTEMS”, Texas A&M university, U.S.A and university of pavia , Italy.  
 M.Akbari, Department of Electrical and computer engineering , payame noor university , Iran.  
 Ong, A. K. and Wooley, B. A. 1997. “A two-path bandpass Sigma Delta modulator for digital IF extraction at 20 MHz”, IEEE J. of Solid-State Circuits, vol. 32, no. 12, pp.1920-34.  
 Singor, W. and Snelgrove, W. M. 1995. “Switched-Capacitor Bandpass Delta-Sigma A/D Modulation at 10.7 MHz”, IEEE J. of Solid-State Circuits, vol. 30, no. 3, pp.184-192,

\*\*\*\*\*