



ISSN: 0976-3376

Available Online at <http://www.journalajst.com>

ASIAN JOURNAL OF
SCIENCE AND TECHNOLOGY

Asian Journal of Science and Technology
Vol. 08, Issue, 11, pp.6669-6676, November, 2017

RESEARCH ARTICLE

SIZING OF AN ELECTRIC ENERGY PRODUCTION HYBRID SYSTEM

***Bati Ernest Boya Bi and Prosper Gbaha**

National Institute Polytechnic Houphouët Boigny, New and Renewable Energies Group, Laboratory of Mechanics and Materials Science, BP1093 Yamoussoukro, Côte d'Ivoire

ARTICLE INFO

Article History:

Received 24th August, 2017
Received in revised form
06th September, 2017
Accepted 15th October, 2017
Published online 30th November, 2017

Key words:

Sizing, Photovoltaic, Hydrogen, Hybrid,
Batteries, Load.

Copyright©2017, Bati Ernest Boya Bi and Prosper Gbaha. This is an open access article distributed under the Creative Commons Attribution License, which permits unrestricted use, distribution, and reproduction in any medium, provided the original work is properly cited.

ABSTRACT

The objective of this work is the sizing of an electric energy production system mainly based on solar panels. The system is composed of a photovoltaic field and an energy storage unit (lead acid batteries, hydrogen-based energy storage unit (HESU), or hybrid storage HESU/batteries). The energy storage unit is requested when there is excess production, or to compensate for the lack of power during peak consumption. The sizing through its tools, allowed us to define solar power, size of battery pack and storage volume of hydrogen needed to meet load concerned.

INTRODUCTION

In most isolated areas, photovoltaic generator is the main source of electrical energy. For these areas, the price of extension of electricity grid is prohibitive and price of fuel increases radically with isolation (Semaoui, 2014). The continued decline of prices of generators based on renewable energy and the increasing reliability of these systems have led to a greater use of renewable energy sources for generation of electricity in isolated areas (Benmessaoud, 2012). One of properties that limits the use of renewable energy is related to variability of resources. Fluctuations in load according to annual or daily periods are not necessarily correlated with resources (Gailly, 2011). For isolated areas, the solution to be chosen is certainly the coupling between several sources, for example wind turbines, photovoltaic panels and fuel cell coupled to an electrolyzer (Darras, 2010). We present in this document the design of PV-HESU-BATT (Photovoltaic (PV)-hydrogen-based energy storage unit (HESU)-Batteries (BATT)) system, from sizing of installation to description of parameters of components most adapted to our application. We describe a technological solution allowing to exploit renewable resources in isolated site, as well as means of sizing of this type of system.

System Architecture

The general architecture of PV-HESU-BATT hybrid system is shown in Figure 1.

*Corresponding author: Bati Ernest Boya Bi,
National Institute Polytechnic Houphouët Boigny, New and Renewable Energies Group, Laboratory of Mechanics and Materials Science, BP1093 Yamoussoukro, Côte d'Ivoire

In an electrical system, various components are generally connected to a network. The type of network (continuous or alternating) depends on its size and chosen application. In the case of small isolated system, the DC network or DC bus architecture may be used. All components are connected according to figure below. The losses in the network are limited by the fact of its size. Moreover, this type of architecture makes it possible to limit losses due to inverters, the presence of which is inevitable in case of the alternating AC network. Here, only the user is connected to bus via an inverter. The storage components as well as PV field are connected to bus via DC-DC converters.

We have therefore studied a system which differs by the type of storage used, consisting of:

- a photovoltaic generator as main source of energy (1);
- a load simulating consumption of end user (2);
- a DC bus (3);
- converters for adjusting voltages to that of DC bus (4);
- an energy storage unit which can be constituted (5):
- a lead-acid battery pack (5a);
- an energy generation and storage system (Fuel cell and accessories, Electrolyzer and accessories) (5b);
- aHESU-Batteries (5c).

Choice of hydrogen storage system

The choice of system is essential in terms of yields and prices. Advice is given for choice of electrochemical components and for architecture of complete system.

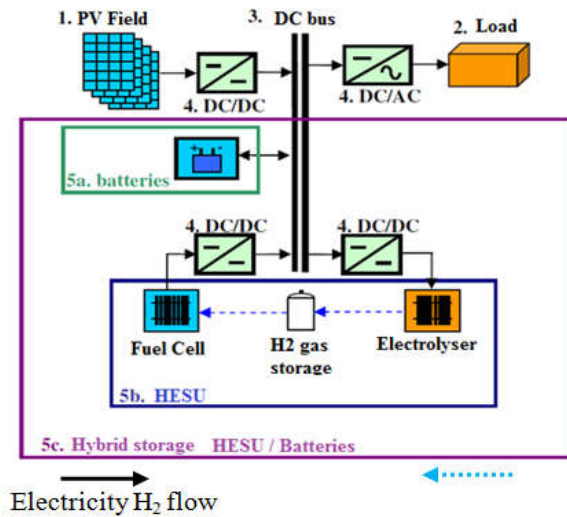

Figure 1. Architecture of the studied systems and the different types of storage

Electrolyzer

Alkaline electrolyzers have very good performances at cell level (potential efficiency: 80%, faradic efficiency: 99%) but necessary device induces a high intrinsic consumption. Membrane electrolyzers have poor cell performance (potential yield: 70%, faradic yield: 90%). On other hand, their control is simple. The reported lifetimes are equivalent for both technologies at 25 years for alkaline electrolyzer and 150 000 hours for PEMFC (Labbé, 2006). Alkaline technology seems preferable because optimization of device will achieve best overall yields. It is preferable to use a high pressure electrolyzer to avoid use of an energy-consuming compressor to reduce size of gas storage unit.

Fuel cell

We will opt for the PEMFC type battery, in spite of its efficiency lower than that of SOFC battery, for the following reasons:

- Very fast starting time;
- Very fast response time;
- Compactness;
- Low temperature operation;
- Insensitive to CO₂;
- Strong structure.

Complete system Architecture

In a hybrid system of energy production, three parameters must be studied carefully to optimize system:

- The system sizing, which allows to define power of components and size of storage in order to meet electrical demand;
- The choice of electrical architecture is very important in terms of efficiency;
- Finally, a good energy management strategy within system allows rational use of various components.

Methods of sizing simulated systems

For sizing of components, the following parameters must be defined:

- The peak power of photovoltaic field;
- The nominal power of electrolyzer and fuel cell components;
- The nominal capacity of battery storage;
- The volume of gas storage.

The analysis of functioning of system and its components makes it possible to predetermine part of these parameters. The remainder of these parameters are determined by optimization routines in order to complete definition of system in terms of sizing. The assumptions and criteria used will be detailed in following paragraphs.

Sizing Assumptions for Storage Components

Electrolyzer system: The nominal power of P_{nomel} electrolyzer system is set, proportional to peak power of PV field.

$P_{\text{nomel}} = K_{\text{el}} \times P_{\text{(peak PV)}}$, Where value of K_{el} coefficient depends on type of storage used.

Case of HESU storage alone

When energy storage is only via hydrogen (PV-HESU system), to maximize hydrogen production, P_{nomel} must be equal to maximum of power produced by PV field. Indeed, if all solar resource is available, and in order to lose as little as possible, it must be possible to completely supply it to electrolyzer (to losses in converters by) in order to store it.

HESU-BATT Hybrid Storage Case

When hybrid storage is used, hydrogen requirements are lower because battery storage provides some of energy demand. There is therefore an interaction between dimensional parameters K_{el} for electrolyzer and C_{nom} for batteries, the appropriate values of which have been determined following a sensitivity study (J. LABBE, 2006). Finally, the K_{el} coefficient was set equal to 0.8 thus reducing installed power of electrolyzer. The following table shows values of K_{el} parameter according to system considered (Labbé, 2006).

Table 1. K_{el} parameter values according to system under consideration

System	PV-HESU	PV-HESU-Batteries
K_{el}	1	0.8

Fuel Cell System

Whatever storage system used, nominal power of fuel cell system is fixed in such a way that it can in any case ensure supply of energy to load. Thus we have:

$$P_{\text{nomfc}} = K_{\text{fc}} \times P_{\text{maxload}}$$

The coefficient K_{fc} was introduced in order to take into account losses in converters

DC-DC and DC-AC. The observation of converter yields during one year of simulation made it possible to evaluate value of coefficient K_{fc} (Arab Hadj and al., 1995). And finally, we pose :

$$K_{\text{fc}} = 1,1$$

The Batteries system

The available capacity of battery pack must satisfy autonomy of system over a few days during most unfavorable period in terms of end-user consumption in relation to photovoltaic production. Normalized coefficients expressing correlation between load and sunshine were introduced in this study. They account for ability of sunshine to provide end user. They allow us to locate worst period of year to calculate size of battery pack. The correlation coefficients first evaluate quantity of energy Q_1 that batteries should provide to user during day when his consumption is highest relative to lowest production of PV field. In order to take account of $T_{\text{useful_batteries}}$ utilization rate of battery pack (defined by difference between minimum and maximum authorized states SOCmin and SOCmax), quantity of energy Q_2 that batteries must actually store is then calculated :

$$Q_2 = \frac{Q_1}{T_{\text{useful_batteries}}}$$

Finally, quantity of real energy to be disposed of battery pack denoted Q_{need} is given by the following relation:

$$Q_2 = Q_{\text{need}} \times nd_{\text{autonomy}}$$

Where nd_{autonomy} is number of days during which autonomy of system is considered.

In case of battery storage alone (PV-BATT system), this autonomy is set at four days. In case of hybrid storage system (PV-HESU-BATT system), number of days of autonomy was fixed at one day during worst period in terms of consumption. This reduction in autonomy is justified by fact that in case of hybrid storage, presence of HESU can satisfy additional energy required for autonomy of final consumer.

Converters

The nominal powers of converters correspond to the nominal powers of components to which they are connected.

Electrical architecture and control strategy

To optimize performance of system, simple rules of operation can be enacted:

- PV provides maximum available power;
- The power of PV is preferred over that of fuel cell and lead-acid batteries, which serve only as a supplement;
- The electrolyzer and battery must never operate at same time.

Many electrical configurations are possible: DC bus, AC bus and all intermediate configurations. The AC bus offers significant modularity but overall efficiency of installation can be low (Busquet, 2003). The only solution to control power supplied by each of three generators (PV, lead-acid batteries and fuel cell) is to integrate two power converters supplying a continuous stage. In addition, DC stage must have a high voltage to reduce ohmic losses. The selected electrical architecture is therefore a single-phase high-voltage DC bus to which components are connected via voltage converters. The operating voltages of generators must be as high as possible in

order to minimize losses in converters (300 VDC). To obtain maximum power of PV field, voltage of solar field is simply fixed, avoiding implementation of a complex control strategy (MPPT). The input voltage is nominal voltage of solar field.

Sizing of PV field

Case of PV-HESU and PV-HESU-BATT systems

The sizing of peak power of installed PV field is determined by an optimization algorithm (dichotomy) so that energy initially present in storage (at beginning of simulation year) is equal to that present in end of simulation. This reflects energy autonomy of system over year of operation. In case of PV-HESU and PV-HESU-BATT systems, observed energetic variable corresponds to hydrogen quantity (number of moles) in gas storage. This quantity is first set at a high threshold. The peak power of PV field is then determined so that, over year, hydrogen production by electrolyzer (supplied by PV field) equals consumption by fuel cell system (which feeds final user), ie change in amount of hydrogen in storage must be zero overall over year. For PV-HESU-BATT system, energy management algorithm ensures that state of charge of SOC battery storage does not exceed minimum and maximum authorized limits SOCmin and SOCmax. This quantity of energy is therefore well taken into account by sizing algorithm of PV field.

Case of the PV-BATT system

For PV-BATT system, approach is significantly different. The peak power of installed PV field is calculated by optimization so that state of charge of the SOC battery system does not exceed minimum authorized limit SOCmin. Here, it is energy management algorithm that ensures that SOC storage conditions are met. This difference in design of PV field is explained by fact that battery storage is used on a daily basis.

Sizing of gas storage volume

Once sizing of PV field has been carried out, initial quantity of hydrogen necessary for autonomy of system must be defined. The sizing is carried out in relation to one month during a typical year. Our sizing procedure consists of calculating total amount of hydrogen produced by water electrolyzer and average total amount of hydrogen consumed by fuel cell. The difference between two quantities in every month corresponds to storage volume.

Energy management algorithms

Our approach is inspired by control of Ulleberg installation (F. Laurencelle and al, 2001). An energy management algorithm has been developed for our system. The energy balances are always carried out at level of common bus connecting various energy components of system. The priority is supply of energy demanded by user from energy produced by photovoltaic field.

Two scenarios are presented

1) If power required by load is less than available solar power, then two sub-cases are:

- The operating conditions permit storage of this surplus;
- The surplus cannot be stored (consumed neither by battery nor by electrolyzer) and this causes the increase

of the voltage of solar field, thus reducing intensity and power delivered by renewable generator.

2) If power demanded by load is greater than available solar power then, additional energy must be provided by storage. In this case, loading of storage is then forced to respect operating parameters of components.

Case of Batteries storage only

The batteries are loaded in a limited range of states of charge (SOC) with respect to all stored energy. Indeed, their protection must be ensured by avoiding excessively extreme states of charge, which are partly responsible for premature aging of batteries. In case of an actual system, protection of batteries is generally ensured by monitoring their voltage. They are disconnected if their voltage exceeds previously set Umin and Umax terminals. This process requires a monitoring of their voltage at each instant. It is not reproducible in our simulation environment, whose time step is 10 minutes. We therefore check correct operation of batteries by imposing thresholds of state of charge not to be exceeded. Also, a minimum state of charge SOCmin has been set at 30% of total capacity of battery pack (Cnom). The corresponding voltage is about 11V for a discharge current of 60 A. Similarly, a maximum charge state SOCmax has been set at 92% of Cnom. The corresponding voltage is then about 14V for a load current of 10 A.

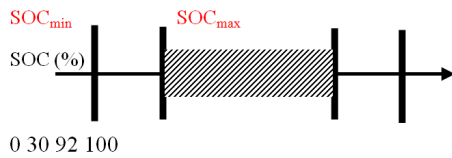

Figure 2. Allowable operating range for batteries used as single storage

Case of HESU alone

The fuel cell system operates without special constraints throughout its power to its nominal power Pnomfc). On other hand, electrolyzer has a minimum operating power. When it operates below this power, the quality of the gases produced is no longer assured (Labbé, 2006). For safety reasons, minimum operating power of Pminel electrolyzer is set at 10% of its rated power Pnomel.

Case of Hybrid storage HESU and Batteries

As in case of single storage, batteries are loaded with respect to the minimum and maximum permitted states (SOCmin and SOCmax). Here, two states of intermediate operating load are introduced: SOCmin1 and SOCmax1. With regard to HESU, minimum and maximum operating powers are introduced for fuel cell and electrolyzer components: Pminfc, Pmaxfc, Pminel and Pmaxel. The energy management algorithm must determine which component to use. This decision is taken according to following considerations:

- When batteries are loaded as a priority

When $SOC_{min1} < SOC < SOC_{max1}$ (hatched area), batteries are discharged or loaded as a priority, depending on excess or

solar deficit. The intermediate minimum and maximum charge states SOCmin1 and SOCmax1 have a respective value of 50 and 90% of Cnom.

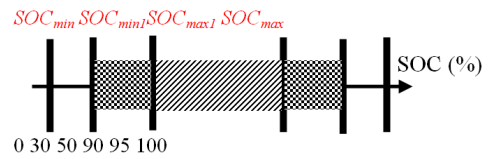

Figure 3. Allowable operating range for batteries in hybrid storage

Here, maximum permissible charge state was set at 95% of Cnom. The charge state area between SOCmax1 and SOCmax will only be reached occasionally. The SOCmax value can thus be increased by 92% for batteries only, 95% for hybrid storage, in order to slightly increase range of use of batteries and thus reduce their size without producing significant degradation.

In case of choice between HESU and batteries

When state of charge of batteries is out of this range (checked area, figure. 3), algorithm then decides which battery or HESU is to operate. The power level to be exchanged with storage is then considered.

Let α be difference between power produced by PV field and power demanded by user:

- $\alpha = P_{pv} - P_{load}$
- α is positive when there is surplus solar
- α is negative when there is deficit solar. For cases detailed below, we will consider quantity $|\alpha|$.
- When $\alpha < P_{minel}$ or $|\alpha| < P_{minfc}$, batteries are solicited.
- When $P_{minel} < \alpha < P_{maxel}$ or $P_{minfc} < |\alpha| < P_{maxfc}$, the HESU is requested.
- When $\alpha > P_{maxel}$ or $|\alpha| > P_{maxfc}$, HESU is solicited up to maximum operating power of components (P_{maxel} and P_{maxfc}). Batteries ensure provision or storage of power complement remaining.

The following diagram illustrates, for hybrid storage case, operating ranges.

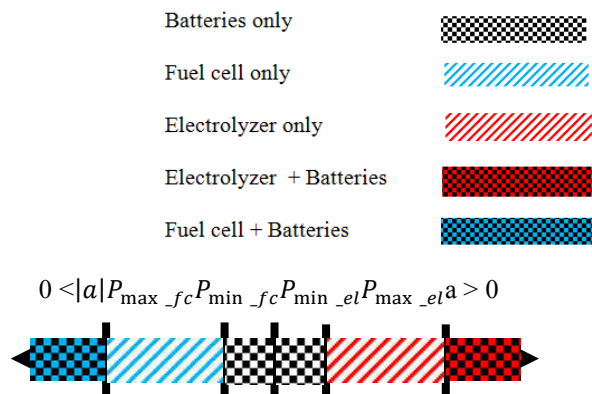

Figure 4. Different operating ranges of components for hybrid storage

Parameters Pminel and Pmaxel were respectively set at 10% and 80% of nominal power of electrolyzer.

Parameters P_{minfc} and P_{maxfc} have been set at 10% and 100% of nominal power of fuel cell system.

Conclusion

In batteries storage case alone, energy management allow batteries to be used daily, ensure their recharging, as well as their protection. This type of management allow to install a batteries pack of low energy capacity, since installed capacity will be recycling great number of times over of year.

Simulator Inputs and Outputs

To simulate one year of operation necessary input data are three annual profiles:

- Load profile;
- Sunshine profile;
- Ambient temperature profile;
- Parameters of components.

For load, input profile is an active power vector (in Watt peak) sampled in ten-minute time steps.

For solar radiation, an annual total solar irradiation profile (in $W.m^2$) is provided, as well as a ten-minute time step.

Many parameters must be entered before starting simulation. They can be divided into two categories:

- Characteristic parameters of components, fixed;
- Dimensional parameters of components that will be adjusted during design phases.

Load Profiles

The application considered here corresponds to an individual housing load in an isolated site (autonomous over a year of operation). The approach adopted for this study is purely deterministic. Probable hazards at load level (occasional peak loads) are not taken into account, aim being to study proposed system as a function of climatic conditions. The synthesized annual load profiles have a ten minute time step and start on first January of year. Their construction is based on a sinusoidal function of time, whose phase shift and amplitude vary daily and seasonally.

Five parameters define set of load profiles (see following figures):

- Annual average power (set at 1 kW);
- Seasonal amplitude (10, 20, 30, 40 and 50% of the annual average power);
- Seasonal phase shift (30 or 210 days, corresponding to a higher consumption in winter or summer);
- Daily amplitude (20, 40, 60 and 80% of daily average power);
- Daily phase shift (0, 4, 8 and 12 hours).

One hundred and sixty load profiles are thus generated ($5 \times 2 \times 4 \times 4$). Figures 5 and 6 show on the profiles different amplitudes and different phase shifts.

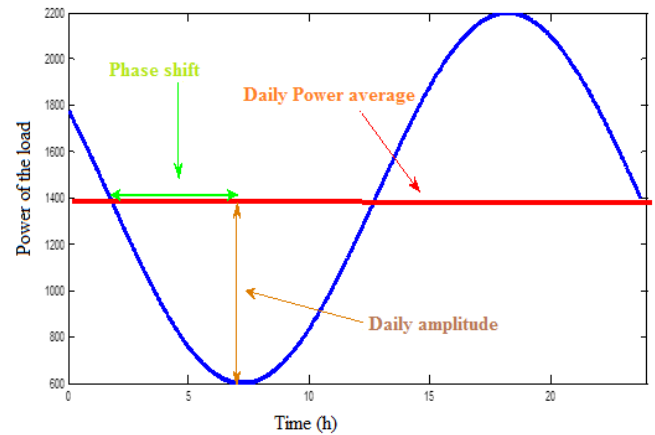

Figure 5. Daily load profile

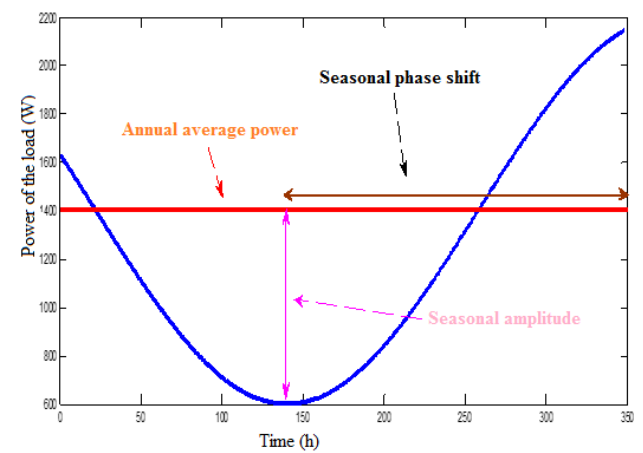

Figure 6. Annual load profile

Sunshine profiles

Parameters related to sunshine

When installing a photovoltaic field, several parameters must be defined beforehand, and among them

- its incline with respect to a horizontal plane;
- its orientation with respect to the cardinal points (azimuth);
- the albedo of surrounding environment (mean index of reflexivity of place).

The choice of incline and azimuth of photovoltaic panels depends on consumption profile of installation and therefore needs of end user.

Incline

The slope allows to adjust solar energy captured according to season. In northern hemisphere, low slopes maximize field production in summer, and conversely, high slopes maximize winter production. It is also possible to determine for data location and profile of data annual solar irradiation, a slope maximizing solar energy capture over year. Figure 7 shows an example of variations of solar irradiation as function of incline of PV field, on first January of a typical year, at Yamoussoukro (azimuth: directly south).

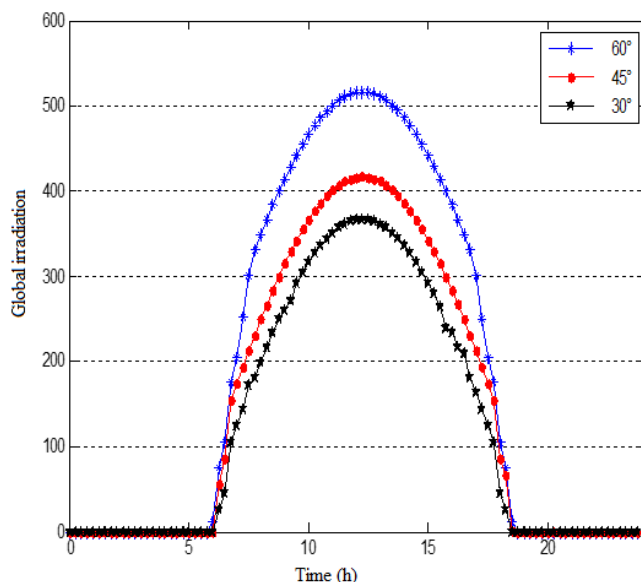

Figure 7. Variation of solar irradiation as function of incline of solar panels; For a January day for a typical year at INP-CENTRE (Yamoussoukro)

Table 2. Daily energy available according to inclination; the month of January for a typical year at INP-CENTRE

Incline	30°	45°	60°
Daily energy	2335	2542	2725

The daily solar energy available for this same day and at the same location is shown in Table 2. It is verified that in winter, more inclined field, more available solar energy is.

Choice of inclination

The choice of incline of panels depends therefore on energy consumption profile of end user, but also on storage system under consideration. If a seasonal storage is used, incline of solar panels is set so as to maximize energy capture over year. In case of daily storage, incline is then set so as to maximize energy capture during most unfavorable periods in terms of availability of renewable resource associated with high consumption by end user. In these cases, these periods generally correspond to a winter month, where availability of resource is low (days of short sunshine, unfavorable weather conditions) while consumption is higher (greater lighting requirements).

Azimuth

The azimuth makes it possible to adjust capture to daily level. The maximum solar irradiation generally occurring at noon (sun at zenith), a south-facing orientation (in northern hemisphere) thus allows maximum solar energy to be collected at time of maximum irradiation. By directly using energy captured by the PV field, if needs of a user are more important in morning, we prefer to orient panels to southeast to maximize capture at this time of day.

Sunshine profiles

The sunshine profiles used in our simulations come from database SoDa (SoDa, <http://www.soda-pro.com/web-services/radiation/cams-mcclear>). These are profiles of

"typical" years, synthesized on basis of actual measurements taken over several years. The data collected with a time step are global sunshine (W / m^2) and ambient temperature ($^{\circ}C$). The data is then interpolated to generate profiles with a ten minute time step. A geographical location was chosen. It has a longitude (5.1° west longitude), and azimuth (directly south). In fact, there will be two profiles of sunshine, corresponding to incline maximizing energy capture:

- Over year (tilt 1),
- Or worst period (tilt 2).

The inclines in question are determined by a service of SoDa database.

The following table shows location information.

Table 3. Location coordinates and associated inclines

INP-CENTRE	
Latitude	6°51'53" north
Incline 1	30°
Incline 2	60°

Simulation Parameters

The following tables present input parameters of simulator for each component of studied systems. The variables in bold correspond to parameters whose values are determined by sizing algorithms.

Simulation Time Parameters

Parameter name	Value	Unit	Description
t_{max}	24×365	Hour	Simulation duration

PV field parameters

Parameter name	Value	Unit	Description
N_{pv}	18	without unit	Solar module number
P_{max}	165	W	Maximum power of a module
μ	-0.0043	W. $^{\circ}C^{-1}$	Coefficient of module power variation with the temperature
NOCT	47.1	$^{\circ}C$	Operating temperature of solar modules under standard conditions
$P_{peak-PV}$	$N_{pv} \times P_{max}$	W	peak power installed of PV field

Lead acid battery blok Parameters

Parameter name	Value	Unit	Description
$U_{Bat,nom}$	12	V	Nominal voltage of a unit block
C_{nom}	140	Ah	Nominal capacity of a unit block
I_{nom}	14	A	nominal current discharge
ns	4	no	Number of branches in series
np	1	no	Number of branches in parallel (in case of hybrid storage HESU-batteries: 1 day of autonomy without sun).

Different states of charge (SOC) of battery pack

Parameter name	Value	Unit	Description
SOC_{min}	30	% C_{nom}	Minimum SOC authorized
SOC_{max}	95	% C_{nom}	Maximum SOC authorized
SOC_{min1}	50	% C_{nom}	Minimal intermediate SOC
SOC_{max1}	90	% C_{nom}	Maximum intermediate SOC

Electrolyzer Parameters

Parameter name	Value	Unit	Description
P_{nom_el}	3600	W	Initial nominal power
N_{cel_el}	5	no	Number of cells
		Unit	
A_{el}	0.025	m ²	Cell surface
π_{el}	7	bar _{abs}	Operating pressure of electrolyzer

Dimensional coefficient of electrolyzer

Parameter name	Value	Unit	Description
P_{nom_el}	$K_{el} \times P_{peakpv}$	W	Nominal power after sizing
With HESU as single storage :			
K_{el}	1	No unit	Electrolyzer scale factor
With hybrid storage HESU-batteries			
K_{el}	0.8	No unit	Electrolyzer scale factor

Operating power of electrolyzer

Parameter name	Value	Unit	Description
P_{min_el}	$0.1 \times P_{nom_el}$	W	Minimum authorized power
P_{max_el}	P_{nom_el}	W	Maximum authorized power

Fuel cell parameters

Parameter name	Value	Unit	Description
P_{nom_fc}	3600	W	Initial nominal power
N_{cel_fc}	96	No unit	Number of cells
A_{fc}	0.01	m ²	Cell surface
$\pi_{fc_H_2}$	3	bar _{abs}	Operating pressure on hydrogen side of fuel cell
$\pi_{fc_O_2}$	3	bar _{abs}	Operating pressure on oxygen side of fuel cell
Nb_{fc}	1	No unit	Number of fuel cells started according to load to be supplied

Fuel cell operating power

Parameter name	Value	Unit	Description
P_{min_fc}	0	W	Minimum power

Hybrid storage HESU-batteries

Parameter name	Value	Unit	Description
P_{min_el}	$0.1 \times P_{nom_el}$	W	Minimum authorized power
P_{max_el}	P_{nom_el}	W	Maximum authorized power

Gas Storage Tank Settings

Parameter name	Value	Unit	Description
V	4	m ³	Volume of tank
P_0	101320	Pa	Atmospheric pressure in standard conditions
P_{stock_min}	3	bar _{abs}	Minimum pressure in tank
P_{stock_max}	7	bar _{abs}	Maximum pressure in tank
R	8.314	SI	Perfect gas constant

Converter parameters

Parameter name	Value	Unit	Description
$\eta_{10_DC/DC}$			Yield at 10% of rated power of DC-DC converter
	93	%	
$\eta_{100_DC/DC}$			100% rated output of DC-DC converter
	98	%	
P_{nom_DC/DC_PV}	P_{max_charge}	W	Nominal power of PV field DC-DC converter
P_{nom_DC/DC_EL}	P_{nom_el}	W	Nominal power of DC-DC converter of electrolyzer
P_{nom_DC/DC_FC}	1.1	W	Nominal power of DC-DC converter of fuel cell
	$\times P_{max_char}$	W	

Inverter Parameters

Parameter name	Value	Unit	Description
η_{10_ond}		%	Output at 10% of inverter nominal power
	86	%	
η_{100_ond}		%	100% efficiency of inverter rated power
	97	%	
P_{nom_ond}	P_{max_charge}	W	Inverter nominal power

Conclusion

The sizing makes it possible to obtain a good overall functioning and to limit the cost of installation. Simple rules determine relationships between powers of components. Sizing tools allow us to define solar power and storage volume needed to respond to a load in a given site. The electrical architecture and control strategy are essential, limiting conversion losses and optimizing energy management within system. The choice of electrochemical components is difficult because it is necessary to find the best compromise between efficiency, reliability and durability. The alkaline electrolyzer is preferable for its efficiency and long life. Its device must be optimized in terms of reliability and intrinsic consumption. The PEMFC stack has been chosen for its fast start-up time, its solid structure, its insensitivity to CO₂ and its compactness. The design and operation of components of hybrid system must take into account changes in the load and renewable resources available to maximize the use of renewable resources. To this end, the sources of HESU studied are sized and then modeled.

REFERENCES

- Arab Hadjand al. 1995. Photovoltaic systems sizing for Algeria. Solar energy 54 (2), p.99-104.
- Benmessaoud, T. M. 2012. Hybrid energy system PV-SOFC stationary realization case study at USTO, Thesis of University of Science and Technology MOHAMED BOUDIAF-ORAN.
- Busquet, S. 2003. Study of an autonomous system of energy production coupling a photovoltaic field, an electrolyzer and a fuel cell: realization of a test bench and modeling, PHD thesis of Ecole des Mines de Paris.
- Darras, C. 2010. Modeling of hybrid system photovoltaic-hydrogen. Isolated site application, micro-grid and electrical grid application as part of PEPITE project (ANR PAN-H), PHD Thesis of CORSE university.
- Gailly, F. 2011. Power supply of an isolated site from a photovoltaic generator associated with a tandem

- electrolyzer / fuel cell (H₂ / O₂ batteries), PHD Thesis of Toulouse National Polytechnic Institute.
<http://www.soda-pro.com/web-services/radiation/cams-mcclear>
- Labbé, J. 2006. Electrolytic hydrogen as mean of electricity storing for isolated photovoltaic systems, PHD Thesis of Ecole des Mines de Paris
- Laurencelle, F. and al, 2001. Characterisation of Ballard MK-E Proton exchange membrane fuel cell stack, Fuel Cell from fundamentals to systems, N°1, pp. 66-71, 2001.
- Semaoui, S. 2014. Contribution to the study of photovoltaic systems used for the supply of single-family houses in the southern areas of Algeria. *Thesis of Hadj Lakhdar Batna University.*
