



ISSN: 0976-3376

Available Online at <http://www.journalajst.com>

ASIAN JOURNAL OF
SCIENCE AND TECHNOLOGY

Asian Journal of Science and Technology
Vol. 08, Issue, 03, pp.4493-4498, March, 2017

RESEARCH ARTICLE

MOMENTUM TRANSFER WITH COAXIALLY PLACED PERFORATED DISC TURBULENCE PROMOTER IN CIRCULAR CONDUIT

Kanaka Mahalakshmi, K. and *Nageswara Rao, V.

Department of Chemical Engineering, Andhra University, Visakhapatnam, India

ARTICLE INFO

Article History:

Received 06th December, 2016
Received in revised form
08th January, 2017
Accepted 12th February, 2017
Published online 31st March, 2017

Key words:

Momentum transfer,
Turbulence promoter,
Perforated disc promoter

ABSTRACT

Studies on the effect of coaxially placed entry region perforated disc assembly as turbulence promoter on momentum transfer rates in forced convection flow of electrolyte were conducted. The study covered a wide range of geometric parameters such as diameter of the disc (D_d), thickness of disc (T_d) and distance of disc from the entrance of test section (h). The results revealed that the friction factor increased with increase in diameter of the disc (D_d), thickness of disc (T_d) and decreased with increase in distance of disc from the entrance section (h). Within the range of variables covered, the increase in friction factors due to the presence of the promoter was significant. At the velocity of 0.3396 m/s, while for the maximum disc diameter the increase was 75 times more than the smooth tube, while for the minimum disc diameter, the increase over the smooth tube was 45 times. Momentum transfer rates were analyzed with *momentum transfer roughness function* $R(h^+)$ and *roughness Reynolds number* (Re^+). The following correlation was reported out of the study.

$$R(h^+) = 0.3536x(Re^+)^{0.2784}(\phi_1)^{-0.0809}(\phi_2)^{-0.0725}(\phi_3)^{0.12329}$$

Copyright©2017, Kanaka Mahalakshmi and Nageswara Rao. This is an open access article distributed under the Creative Commons Attribution License, which permits unrestricted use, distribution, and reproduction in any medium, provided the original work is properly cited.

INTRODUCTION

In one of the earlier studies, the effect of roughness on friction factor and velocity distribution was done by Nikuradse (Nikuradse, 1993) for sand grain roughness. Cope (Cope, 1941) studied heat and momentum transfer for roughness elements and Nunner (Nunner, 1956) studied heat and pressure drop measurements in roughness tubes. Friction and heat transfer measurements for repeated rib roughness in tube flow was done by Sams (Sams, 1956), Burnett (Burgoyne *et al.*, 1964; Koch 1958). Webb, Eckert and Goldstein (Webb *et al.*, 1971) conducted experiments using tube with internal pins and correlated their data in terms of *roughness Reynolds number* (Re^+) and *roughness momentum transfer function* $R(h^+)$.

Dipprey and Sabersky (1963) analyzed their data in terms of roughness function for their experimental study (Sethumadhavan *et al.*, 1983). Conducted experiments for heat and momentum transfer for the tubes with tightly fitted helical wire coils. Most of the works mentioned above utilized the wall similarity concept and correlated their data in terms of *roughness function and roughness Reynolds number* by assuming two regions namely viscous region close to the wall of the tube and turbulent region which existed in the turbulent core away from the surface of the tube.

The same two-region flow assumed in this study also due to the presence of the disc across the tube which generated turbulent core flow and viscous flow at the wall. Correlation of data for the flow with perforated disc as insert promoter in terms of *roughness function and roughness Reynolds number* was not found in the literature. So an attempt was made to correlate the data in terms of $R(h^+)$ and Re^+ using the following type of analysis. Parameters covered in the study were compiled in Table – 1

Experimentation

Schematic diagram of experimental set up was shown in figure 1. It was similar in layout to that used in earlier studies (Venkateswarlu *et al.*, 2000; Sitaraman 1977). It essentially consisted of a storage tank (TS), centrifugal pump (P), Rotameter (R), entrance calming section (E1), test section (T) and exit calming section (E2). The storage tank was a cylindrical copper vessel of 100 liter capacity with a drain pipe and a gate valve (V1) for periodical cleaning. A copper coil (H) with perforations was provided to bubble nitrogen through the electrolyte. The tank was connected to the pump with a 0.025 m diameter copper pipe on the suction line of the centrifugal pump. The suction line was also provided with a gate valve (V2). The discharge line from the pump was split into two. One served as a bypass line and was controlled by the valve (V3). The other was connected to the pump to the entrance calming section (E1) through a Rotameter.

*Corresponding author: Nageswara Rao, V.
Department of Chemical Engineering, Andhra University,
Visakhapatnam, India

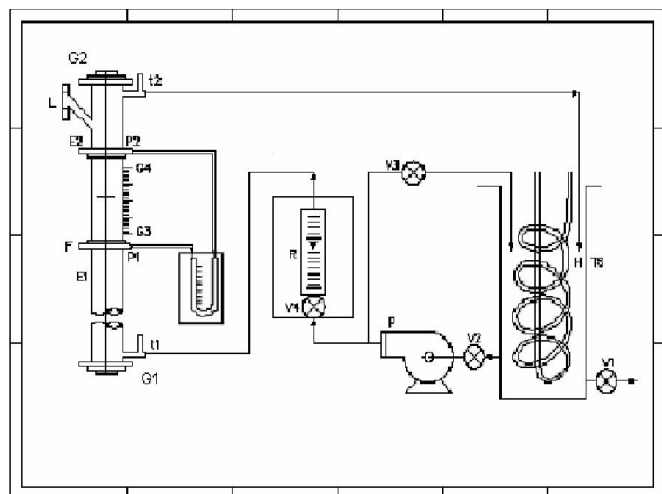

Fig. 1. Schematic diagram of Experimental Setup

Table 1. Range of variables covered in the study

Variable	Minimum	Maximum	Max/Min
Thickness of Disc, Td, m	0.005	0.060	12
Diameter of the of Disc, Dd, m	0.025	0.045	1.8
Distance of Disc from entrance section, h, m	0.14	0.30	2.14
Velocity, m/s	0.024	0.224	9.33
Reynolds number, Re	1285	11985	9.32

The Rotameter was connected to a valve (V4) for adjusting the flow at the desired value. The Rotameter had a range of 0 to $475 \times 10^{-6} \text{ m}^3/\text{s}$. The entrance calming section consisted of 0.05 m ID circular copper pipe with a flange and was closed at the bottom with a gland nut (G). The up-stream side of the entrance calming section was filled with capillary tubes to dampen the flow fluctuations and to facilitate a steady flow of the electrolyte through the test section. The details of the test section was shown in figure2.

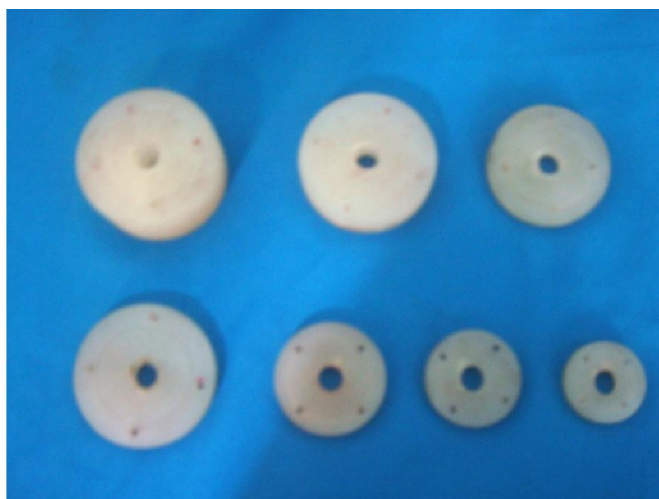
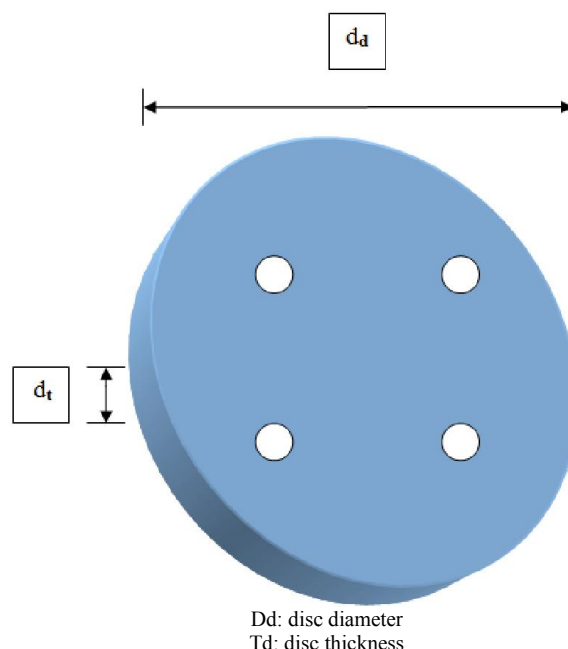

Fig. 2. Turbulency promoters

The test section was made of a graduated Perspex tube of 0.64m length with point electrodes fixed flush with the inner surface of the tube. The point electrodes were made out of a copper rod and machined to the required size. They were fixed flush with the inner surface of the test section at equal spacing of 0.01m. Exit calming section was also of the same copper tube of 0.5 m length in diameter and it was provided with a

flange on the upstream side for assembling the test section. It had gland nuts (G4, G3) at the top and bottom ends to hold the central tube. Two thermo wells (t1, t2) were provided - one at the upstream side of the entrance calming section and the other at the downstream side of exit calming section for measurement of temperature of the electrolyte. Perforated disc made of nylon serving as turbulency promoter was of various sizes with a provision to be fixed rigidly within the test section. The limiting current measuring equipment consisted of multimeter of Motwane make which had 0.01 mA accuracy and vacuum tube voltmeter was used for potential measurements. The other equipment used in circuit was rheostat, key, commutator, selector switch, and a lead acid battery as the power source. The commutator facilitated the measurement of limiting currents for oxidation and reduction process under identical operating conditions by the change of polarity while the selector switch facilitated the measurements of limiting currents at any desired electrode. The circuit diagram used for the measurement of limiting currents was shown in the figure 3.



Dd: disc diameter
Td: disc thickness

Fig. 3. Details of promoter

The following electrode reaction was involved in the study.

Cathodic reduction of ferricyanide ion:

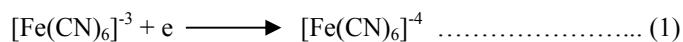

Equimolar solution of 0.01 M Potassium ferri-ferrocyanide couple was chosen along with 0.5N NaOH were prepared. The point electrodes fixed flush with surface of the wall of the cell were used to obtain limiting currents. Initially blank runs were conducted with sodium hydroxide solution alone to ensure that the limiting currents obtained in the subsequent runs were due to diffusion of reacting ions (Ferri-cyanide ion) only. The electrolyte was pumped at a desired flow rate through the test section by operating the control and by-pass valves. On attainment of steady state, potentials were applied across the test electrode and wall electrode in small increments of potentials (100mV) and the corresponding currents were measured for each increment.

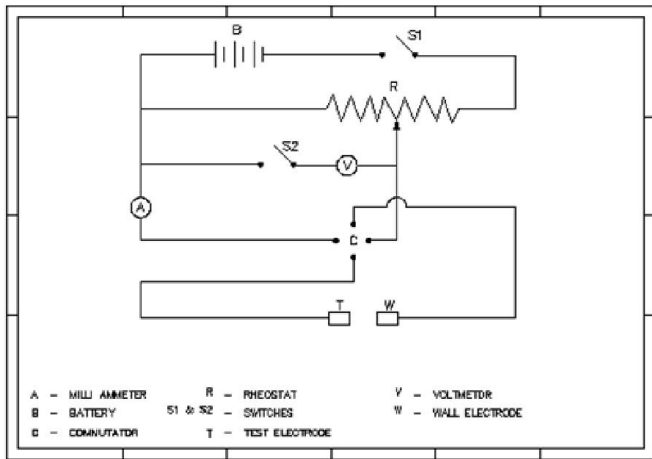

Fig. 4. Circuit diagram

In view of the large area of the wall electrode in relation to the test electrode nearly constant potential was maintained at the test electrode. The limiting currents were obtained from the measurements of applied potential and current as had been done in several earlier works (Venkateswarlu *et al.*, 2000; Sitaraman, 1977; Sarveswara Rao and Raju, 1986; Warren *et al.*, 1993). The attainment of limiting current was indicated by the constancy of current with a large increase in the potential. The perforated disc was placed concentrically in the test section. Pressure drop measurements were taken using an inclined manometer with Carbon tetrachloride as manometric liquid.

RESULTS AND DISCUSSION

The flow of electrolyte through circular conduit with perforated disc as turbulence promoter would generate wakes and eddies. This will enhance mass transfer coefficient and momentum transfer. Enhancement of momentum transfer will increase energy consumption also. An attempt was made to harness the effect of using perforated disc as turbulence promoter with minimum energy consumption. Table 2 indicated the friction factor obtained in this study together with the other works. The friction factors obtained here were comparable to other studies with different turbulence generating systems.

Table 2. Comparison range of Reynolds number with other works

Author	Promoter	Friction factor	Range of Re
T.S. Sitaraman, 1977	String of sphere	0.333-0.131	1000-34000
Yapici <i>et al.</i> , 1997	Swirl generators angles with duct axis		
	15°-45°	0.042-0.031	8900-27000
	60° -70°	0.243-0.117	8900-27000
This work	Perforated disc	0.284-0.168	1300-12000

Analysis of momentum transfer data

Augmentation in mass transfer is accompanied by energy level. An attempt is made to know momentum transfer data which is derived by measuring pressure level by u-tube manometer with pressure tapes placed on either side of the test section. For the measured pressure level effective friction losses are calculated by the following equation

$$\Delta P = (\rho_{\text{fluid}} - \rho_{\text{electrolyte}})(g/g_c) h \dots\dots\dots (2)$$

$$f = \Delta P \cdot d \cdot g_c / 2 \cdot L \cdot \rho \cdot V^2 \dots\dots\dots (3)$$

In the present study energy losses are due to skin friction offered by the wall in addition to from friction offered by disc. Energy factor is defined by the equation

$$EF = (E - E_0) / E_0 \dots\dots\dots (4)$$

E = Energy consumed by using perforated disc as turbulence promoter.

E₀ = Energy consumed by using empty conduit.

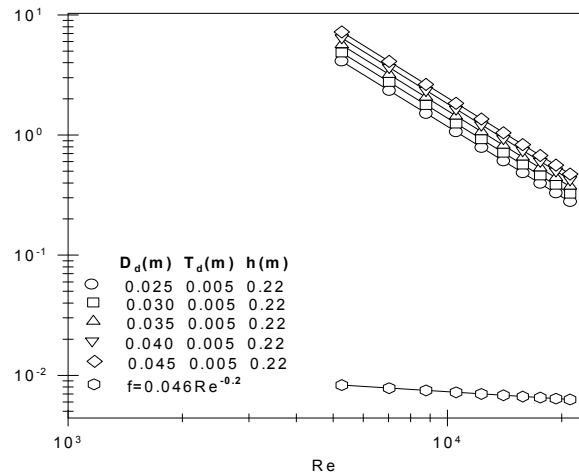

Figure 5. Variation of friction factor with Reynolds number – Effect of perforated disc diameter

Effect of Parameters

A graph is drawn for the friction factor versus Reynolds number and is shown in figure 5. Disc diameter is varied from 0.025m, 0.030m, 0.035m, 0.040m and 0.045m and the corresponding pressure drop and friction factor values are calculated. The graph shows that friction factor increases with increase in disc diameter. The enhancement in friction factor is 45 times at D_d=0.025m to 75.81 times at D_d=0.045m over the predicted values of friction factor from f=0.046 Re^{-0.2} (Warren, 1993) for the empty conduit without promoter at the velocity of 0.3936m/s. The disc diameter has strong influence on friction factor because of fan friction generated in the column together with the skin friction.

Figure 6 shows the variation of energy factor with Reynolds number with disc diameter as parameter. Energy factor (EF) increases as Reynolds number increases. Energy factor is found to increase as disc diameter increases. The variation of friction factor with Reynolds number for studying the effect of thickness of the disc (Td) is shown in figure7. The friction factor increases with increase in thickness of the disc. The increase in friction factor is from 75.8 times to 187 times over smooth tube values of (Warren, 1993) as the thickness of the disc increases from 0.005m to 0.060m at the velocity of 0.3936m/s.

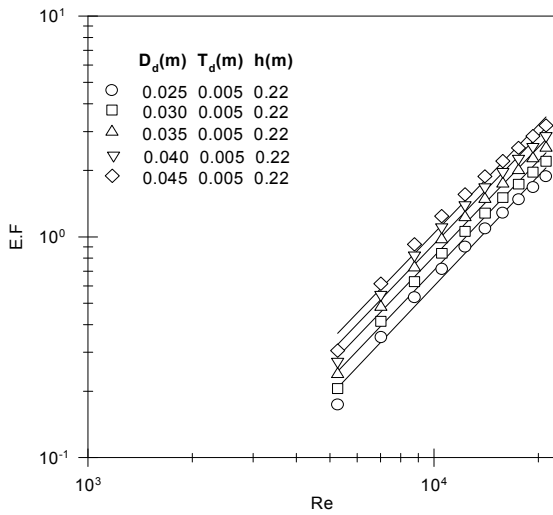

Figure 6. Variation of energy factor with Reynolds number – Effect of perforated disc diameter

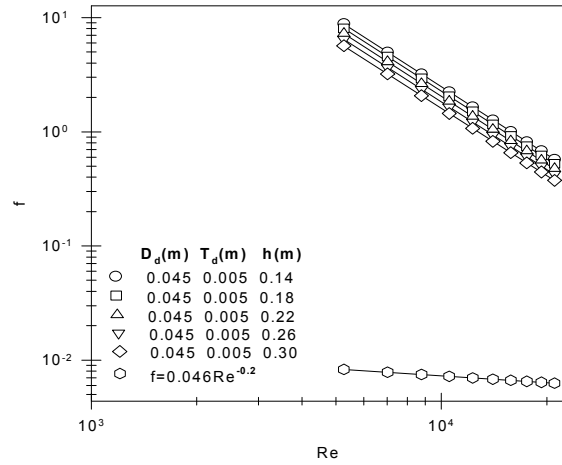

Figure 7. Variation of friction factor with Reynolds number – Effect of distance of disc from entrance of the test section

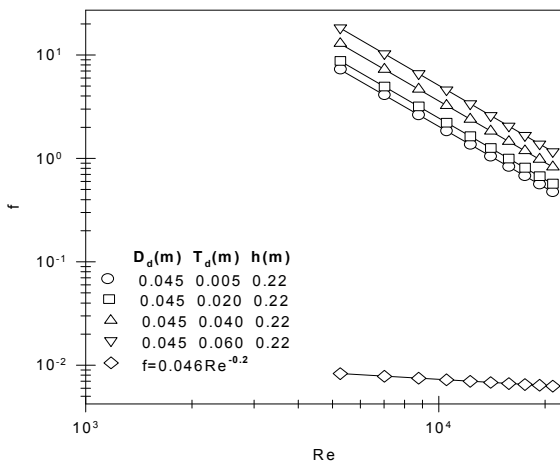

Figure 7. Variation of friction factor with Reynolds number – Effect of perforated disc thickness

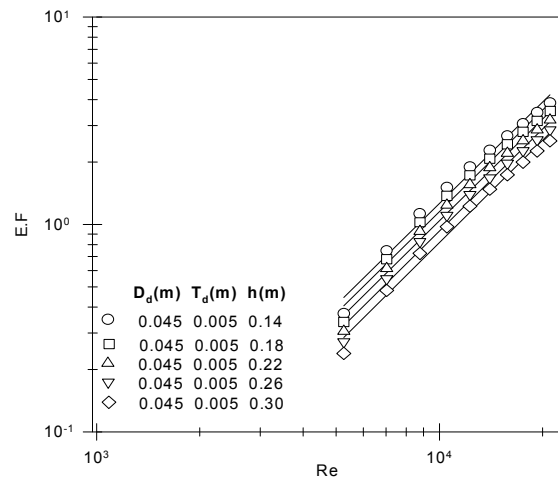

Figure 7. Variation of energy factor with Reynolds number – Effect of distance of disc from entrance of the test section

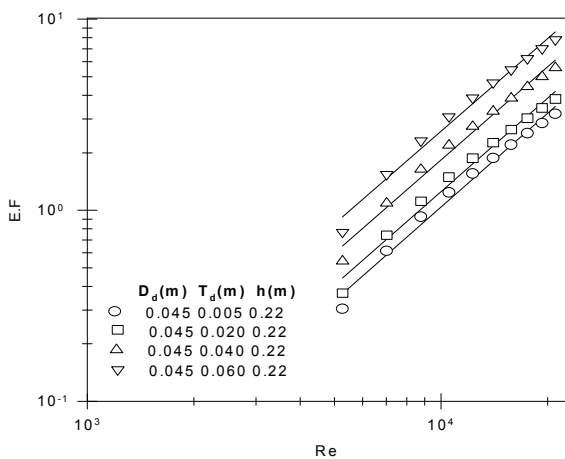

Figure 8. Variation of energy factor with Reynolds number – Effect of perforated disc thickness

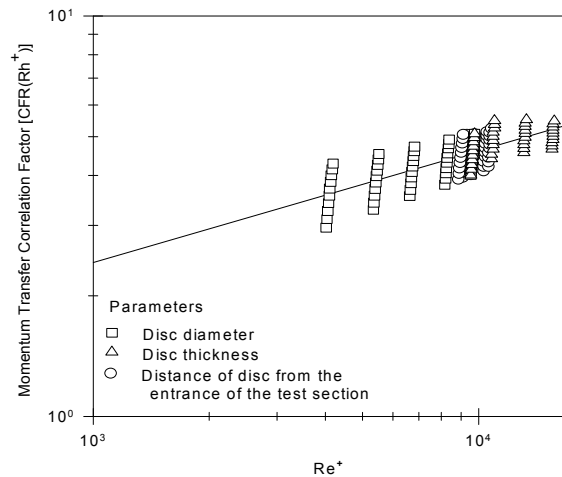

Figure 11. Correlation plot for equation 5.9

Figure 8 shows the variation of energy factor with Reynolds number with disc thickness as parameter. Energy factor increases as the disc thickness increases. It also increases as Reynolds number increases. A graph is drawn for friction factor ‘f’ against Reynolds number (Re) for the set of geometric parameters $D_d=0.045m$, $T_d=0.005m$, for various ‘h’ values and is shown in figure 9.

The graph reveals that the friction factor increases as ‘h’ decreases. The enhancement in friction factor from 59.69 times to 91.93 times over smooth tube values (Warren *et al.*, 1993) as the ‘h’ decreases from 0.30m to 0.14m. It is observed that 0.14m distance is suitable for better performance. Figure 10 shows the variation of energy factor with Reynolds number with ‘h’ as parameter. Energy factor increases as ‘h’ decreases and Reynolds number increases.

Model development

From the measured pressure drop data, friction factor f was calculated using this equation

$$f = \Delta P \cdot d \cdot g_c / 2 \cdot L \cdot \rho \cdot V^2$$

An attempt was made as per the conventional procedure (Venkateswarlu *et al.*, 2000; Sarveswara Rao and Raju, 1986) to correlate friction factor with Reynolds number including dimensionless geometrical groups. The following correlation was obtained.

$$f = 0.7905 \times 10^{-9} \text{Re}^{-1.9652} (\phi_1)^{0.865} (\phi_2)^{0.32601} (\phi_3)^{-0.49148} \dots (5)$$

Average Deviation = 14.77
Standard Deviation = 17.61

This equation obtained for the friction factor vs. Reynolds number which included geometrical groups showed deviation. Therefore an alternative approach was resorted to fit the data with another model. The basic similarity concept assumed the existence of two regions mentioned earlier namely (i) the inner region near the wall where the velocity distribution depended exclusively on the local conditions like y , τ_w , μ , D_d , h and (ii) the outer region away from the wall where direct effect of viscosity on mean flow was negligible. For the inner region near the wall, the dimensionless velocity was given as

$$u^+ = y^+ \dots (6)$$

where $u^+ = u/u^*$

$$y^+ = y u^* / \nu \dots (7)$$

For the outer wall region where the dependency of velocity distribution on molecular viscosity ceased to exist, the velocity distribution would follow the relationship

$$u^+ = 1/k \cdot \ln y^+ + c_1 \dots (8)$$

By the application of boundary conditions $u=0$, $y=y_0$ where y_0 was the thickness of laminar sub layer that would depend on the turbulence generated, equation (8) reduced to

$$u^+ = 1/k \ln y/y_0 \dots (9)$$

The turbulence in the core and at the wall was significantly affected by the geometric parameters of the promoters employed in addition to the fluid velocity. In this case, disc diameter (D_d) was the major characteristic geometric parameter as this was expected to significantly affect the thickness of the laminar sub layer. In this study the parameter D_d was chosen while computing u^+

$$\text{Therefore, } y_0 \propto D_d \dots (10)$$

Equation (9) could be modified as

$$(u_{\max} - u)/u^* = 1/k \ln (y/D_d) \dots (11)$$

Combination of equations (9) and (11) would give the velocity distribution equation for the turbulent dominated part of the wall region

$$u^+ = 2.5 \ln (y/D_d) + R(h^+) \dots (12)$$

Assuming that equation (12) would hold good for the entire cross section of the tube, the friction factor for the turbulent flow inside the tube with perforated disc could be given by integration of equation (12). The generated *roughness function* $R(h^+)$ was given by the following equation,

$$R(h^+) = 2.5 \ln [2 D_d / d] + \sqrt{(2/f) + 3.75} \dots (13)$$

Where $R(h^+)$ is *roughness momentum transfer function*

The resulting format of equation for correlating the momentum transfer data with tape-disc assembly as promoter could now be written as

$$R(h^+) = C_1 (\text{Re}^+)^{b_1} \dots (14)$$

Here, C_1 is proportionally constant and b_1 is an exponent

Re^+ is *roughness Reynolds number* defined by the following equation

$$\text{Re}^+ = (D_d / d) \cdot \text{Re} \cdot \sqrt{(f/2)} \dots (15)$$

Where 'd' is diameter of tube and f is friction factor. By using *roughness momentum transfer function* $R(h^+)$ in place of f and *Roughness Reynolds number* Re^+ in place of Re, the following correlations were obtained by regression analysis. Correlation without incorporating dimensionless geometrical groups could be viewed hereunder,

$$R(h^+) = 2.2732 (\text{Re}^+)^{0.1104} \dots (16)$$

Average deviation = 7.639 Standard deviation = 9.137

The following correlation was obtained by incorporating dimensionless geometrical groups

$$R(h^+) = 0.3536 \times (\text{Re}^+)^{0.2784} (\phi_1)^{-0.0809} (\phi_2)^{-0.0725} (\phi_3)^{0.12329} \dots (17)$$

Average deviation = 6.866, Standard deviation = 8.123
Correlation plot for equation (17) was shown in figure 11.

Conclusion

The momentum transfer data obtained is an important tool for the evaluation of effectiveness of promoter. Based on data of friction factor against Reynolds number, one can carefully analyze frictional losses with geometric parameters. The results reveal that the friction factor increases with increase in velocity and diameter of the disc. Within the range of variables covered, the augmentations achieved in momentum transfer are up to 28 fold over the tube flow in absence of the promoter. From these observations it is found that the effect of perforated disc promoter is considerably high. The data generated and correlation developed are helpful in the design of efficient electrolytic cells without impairing the quality of products.

Nomenclature

Re = Reynolds number = dVp/μ
 Re^+ = *Roughness Reynolds number* = $(Dd/d) \cdot \text{Re} \cdot \sqrt{(f/2)}$

$R(h^+) = \text{Roughness momentum transfer function} = 2.5 \ln(2 D_d / d) + \sqrt{(2/f) + 3.75}$

$u^+ = \text{dimensionless velocity, } u/u^*$

$y^+ = \text{dimensionless radial distance from the wall, } y u^*/\nu$

$f = \text{Friction factor, } \Delta p d g_c / 2LV^2 \rho$

$\Delta P = \text{Pressure difference, N/m}^2$

$d = \text{Diameter of test section, m}$

$D_L = \text{Diffusivity of reacting ion, m}^2/\text{sec}$

$D_d = \text{Disc diameter, m}$

$Td = \text{Thickness of disc, m}$

$g = \text{Acceleration due to gravity, m/sec}^2$

$h = \text{Distance of disc from entrance of test section, m}$

$L = \text{Length of Test section, m}$

$n = \text{Number of electrons transferred}$

$u = \text{Local velocity, m/s}$

$u^* = \text{Friction velocity} = \sqrt{(\tau_w g_c / \rho)}, \text{ m/s}$

$Y_1 = R(h^+) / (\phi_1)^{-0.0809} (\phi_2)^{-0.0725} (\phi_3)^{0.12329}$

Greek letters

$\phi_1 = (Dd/d) = \text{Dimensionless group}$

$\phi_2 = (Td/d) = \text{Dimensionless group}$

$\phi_3 = (h/d) = \text{Dimensionless group}$

$\mu = \text{Viscosity of fluid, Kg/m. sec}$

REFERENCES

- Burgoyne, I.B., Burnett, P. and Wilkie, D. 1964. Forced convection heat transfer data from surfaces roughened by transverse ribs, UKAEA, TRG Report.
- Cope, W. F. 1941. The friction and heat-transmission coefficients of rough pipes, *Proc. Inst. Mech. Engrs.*, 145, vol.99.
- Dipprey, D.P. and Sabersky, R.H. 1963. Heat and Momentum transfer in smooth and rough tubes at various Prandtl numbers, *Int. J. Heat and Mass Transfer*, vol.6, pp329-353.
- Nikuradse, J. 1933. Laws of Flow in Rough Pipes. 1933, VDI FORSCH-Heft 361.
- Nunner, W. 1956. Heat transfer and pressure drop in rough tubes, UKAEA Translation AERE Lib /Trans, 786.
- Sams, E.W. 1956. Heat transfer and pressure drop characteristics of wire-coil type turbulence promoters, USAEC Reactor Heat Transfer Conference.
- Sarveswara, S., Rao, G.J.V.J. Raju, 1986. Studies on Ionic Mass Transfer with co-axially placed cones on a rod in homogeneous fluid and fluidized beds" Paper presented at World Congress III of Chemical Engineers, Tokyo, p481.
- Sethumadhavan, R. and Raja Rao, M. 1983. Turbulent flow heat transfer and fluid friction in helical wire coil inserted tubes, *Int. J. Heat and Mass Transfer*, vol. 26, pp 1833-1845.
- Sitaraman, T.S. 1977. Augmentation of mass transfer with coaxial string of spheres as internals in tubes and fluidized beds" Ph.D. Thesis, University of Madras, India.
- Venkateswarlu, P., Gopichand, T., Raju, G.J.V.J. 2000. Increased mass transfer in a circular column in the presence of disc promoter, *J. Energy Heat Mass Transfer*, 22, pp195-203.
- Warren L. MacCabe, Julian C. Smith, 1993. Peter Harriot Unit Operations of Chemical Engineering, 5thed., McGrawHill, NewYork, p-100.
- Webb, R.L., Eckert, E.R.G. and Goldstein, R.J. 1971. *Int. J. Heat and Mass Transfer*, vol.14, pp. 601-617.
- Yapici, S., Yazici, G., Ozmetin, C., H. Esahan and O. Comakli, 1997. Mass transfer to local electrodes at wall and wall friction factor behavior in decaying turbulent swirl flow, *Int.J. Heat Mass Transfer*, Vo.140, pp.2775-2783.
