



ISSN: 0976-3376

Available Online at <http://www.journalajst.com>

ASIAN JOURNAL OF  
SCIENCE AND TECHNOLOGY

Asian Journal of Science and Technology  
Vol. 08, Issue, 01, pp.4093-4096, January, 2017

## RESEARCH ARTICLE

### A CONTROL SCHEME FOR STORAGELESS DVR BASEDON CHARACTERIZATION OF VOLTAGE SAGS

Poonam Deshmukh, Anant K. Shukla, and \*Pawan C. Tapre

Department of Electrical, S. N. D. College of Engineering & Research Center, Dist. -Nashik

#### ARTICLE INFO

##### Article History:

Received 05<sup>th</sup> October, 2016  
Received in revised form  
14<sup>th</sup> November, 2016  
Accepted 25<sup>th</sup> December, 2016  
Published online 31<sup>st</sup> January, 2017

##### Key words:

Dynamic voltage restorer (DVR),  
Instantaneous symmetrical  
Component theory,  
Phase jump,  
Voltage sag.

#### ABSTRACT

Voltage sag remains a serious power-quality (PQ) problem by being the most common and causing more economic losses. The dynamic voltage restorer (DVR) is a definitive solution to address the voltage-related PQ problems. Conventional topologies operate with a dc link, which makes them bulkier and costlier; it also imposes limits on the compensation capability of the DVR. Topologies with the same functionality, operating without the dc link by utilizing a direct ac-ac converter, are preferable over the conventional ones. Since no storage device is employed, these topologies require improved information on instantaneous voltages at the point of common coupling and need flexible control schemes depending on these voltages. Therefore, a control scheme for DVR topologies with an ac-ac converter, based on the characterization of voltage sags is proposed in this paper to mitigate voltage sags with phase jump. The proposed control scheme is tested on an interphase ac-ac converter topology to validate its efficacy. Detailed simulations to support the same have been carried out in MATLAB, and the results are presented.

Copyright©2017, Poonam Deshmukh et al. This is an open access article distributed under the Creative Commons Attribution License, which permits unrestricted use, distribution, and reproduction in any medium, provided the original work is properly cited.

#### INTRODUCTION

Now a days competition level is more elevate in industrial sector so all industries are generating mass of production in short duration. This is possible due to using fast response devices. So in most of the industries are used electronic devices, passable sensitive devices and electronic drives. These are devices very sensitive to disturbances and become less tolerant to power quality problems. It is most importance issue. The most common power quality problems are voltage disturbances in industrial distribution systems. The voltage sags and swells are the main voltage disturbances that can be due to (i) disturbances in the transmission system, (ii) adjacent feeder faults and (iii) fuse or breaker operation. The voltage-sensitive loads in factories, buildings, and hospitals are damaged due to these disturbances, it results substantial economic data losses. Voltage swell is defined as a short duration increase in rms supply with an increase in voltage ranging from 1.1p.u. to 1.8p.u. of nominal supply. The main reasons for voltage swells are switching large capacitors or the removal of large loads Voltage is momentary decrease in rms ac voltage at the power frequency of duration from 0.5 cycles to few seconds. Voltage swell and sag are caused by short circuit fault, such as line to ground fault and startup of large induction motor.

A series connected custom power device to mitigate voltage sag as well as swell, dynamic voltage restorer is used. Inject the voltage of required magnitude, phase angle and frequency in series with the distribution feeder to maintain the desired amplitude and waveform even when voltage is distorted or unbalance, is the basic function of dynamic voltage restorer. Basically DVR is the power electronics device. Only 10% voltage sag remain in circuit for 5-10 cycles gives damage in critical load. Due to symmetrical and unsymmetrical fault, voltage sag arises in system. Harmonics in supply voltage can be caused due to uncompensated non linear load. For mitigation of problem caused due to caused due to poor quality of power supply, DVR is used their primary application is to compensate for voltage sags and swells. A very simple and practical method for voltage swell and sag detection is by calculating RMS voltage for one or half cycle. DVR topologies does not match with control algorithms many of them are work either by taking instantaneous voltage at the point of common coupling which eliminates the use of dc link in the system.

#### Voltage sag characteristics

Voltage sag is defined as a decrease in rms voltage at the power frequency for durations of 0.5 cycles to 1 minute which gives the parameters of voltage sag like rms voltage and duration. This also give a numerical value to a sag, the recommended usage is a sag 70%, which means that the

\*Corresponding author: Pawan C. Tapre

Department of Electrical, S. N. D. College of Engineering and Research Center, Dist. -Nashik, India.

voltage is reduced down to 70% of the total voltage, thus a remaining voltage is 30%. Sag magnitude is defined as the remaining voltage during the fault. The power systems faults cause a drop in voltage magnitude also cause change in the phase-angle of the system voltage. The parameters used to characterize voltage sag are magnitude, duration, point-on-wave initiation and phase angle jump.

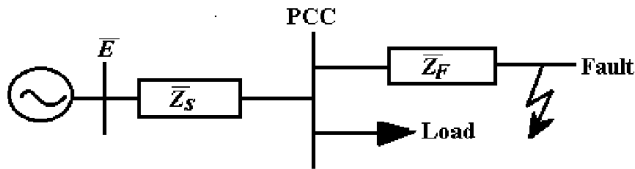

Fig. 1. Single phase model for the voltage sag at the PCC

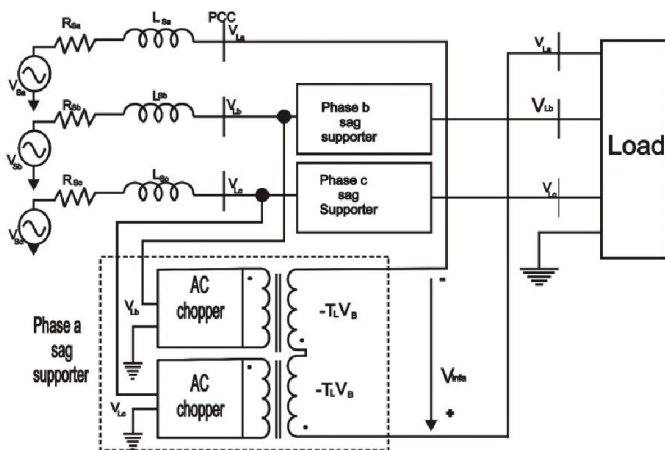

Fig. 2. Interphase ac-ac topology

**Voltage Sag Magnitude**

Determine the magnitude of voltage sag in number of ways. The most common method for obtain the sag magnitude is by using rms voltage. Some other alternatives are also there, e.g. fundamental rms voltage and peak voltage. Hence the magnitude of the sag is considered as the residual voltage or remaining voltage during the event. In the case of a three phase system, voltage sag can also be characterized by the minimum RMS-voltage during the sag.

**Types of voltage sag**

Four basic types of voltage sag shown in figure.

If the voltage deep is equal in all the three phases then it is called symmetrical sag and it comes under type A sag, If the deep is unequal ,it is called unsymmetric and it comes under type B sag lowest remaining voltage is used to characterize the sag. The phase to phase sag at star connected load called type C sag and sag at the terminals of a delta connected load. It is again divided into various sub -types.

**Point on Wave**

For obtaining exact value of swell and sag duration, start and end of the sag with a great precision is needed. For that one needs to find the so-called “point-on-wave of sag initiation” and the “point-on-wave of voltage recovery”. The point-on-

wave initiation is the phase angle of the fundamental wave at which the voltage sag starts.

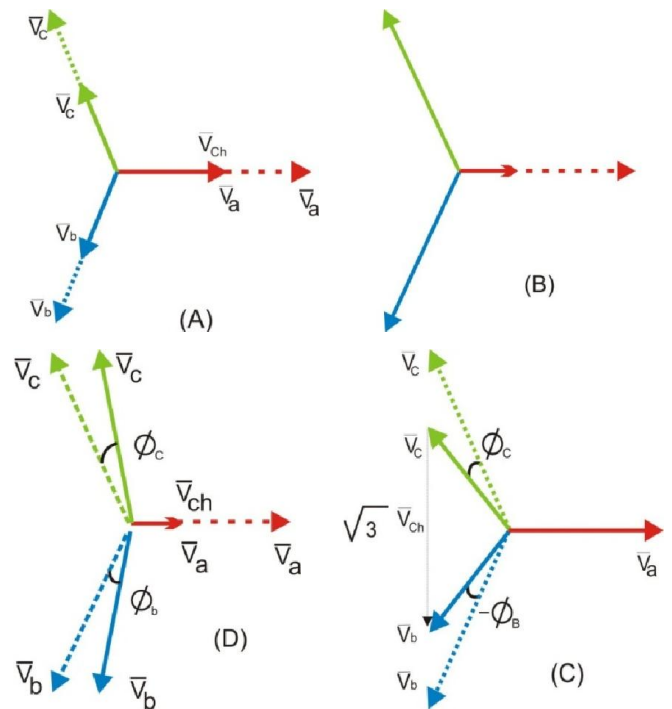

Fig. 3.Types of Sag

**Phase Angle Jump**

A short circuit in a power system not only causes a drop in voltage magnitude but also a change in the phase angle of the voltage. In a 50 Hz system, voltage is a complex quantity which has magnitude and phase angle. A change in the system, like a short circuit, causes a change in voltage. This change is not limited to the magnitude of the voltage but includes a change in phase angle as well. The phase angle jump manifests itself as a shift in zero crossing of the instantaneous voltage Voltage Sag Duration. The duration of voltage sag is mainly determined by the fault-clearing time. The duration of a voltage sag is the amount of time during which the voltage magnitude is below threshold is typically chosen as 90% of the nominal voltage magnitude.

**Characterization Algorithm**

The algorithm combines instantaneous symmetrical component theory and Fourier transform to extract fundamental symmetrical components. Instantaneous symmetrical components that reflect the instantaneous changes in voltages are used to detect disturbances in a system .The sequence components are calculated as follows

$$V_{a0} = \frac{1}{3}(v_a + v_b + v_c)$$

$$V_{a1} = \frac{1}{3}(v_a + av_b + a^2v_c)$$

$$V_{a2} = \frac{1}{3}(v_a + a^2v_b + av_c)$$

Where ;a = 120°, va0, va1 and va2 are the instantaneous zero-, positive-, and negative-sequence components, respectively, va1

and  $v_{a2}$  are complex and time varying quantities; and  $v_a, v_b$  and  $v_c$  are instantaneous three-phase voltages at the PCC. To work in the presence of harmonics and distortions, Fourier transform is applied on the instantaneous symmetrical components of the voltage at the PCC.

**Switching Logic**

The generation of switching logic for interphase ac-ac converter topology, which draws energy from the other two phases to compensate voltage dip in a phase, is elucidated here. There are three sectors I, II, and III as in Fig. 4(a), each comprised of two inverted phase voltages, and they represent phase, and sag supporters, respectively. The phase- sag supporter (sector I) with active vectors and reference voltage is shown in Fig. 4(b).

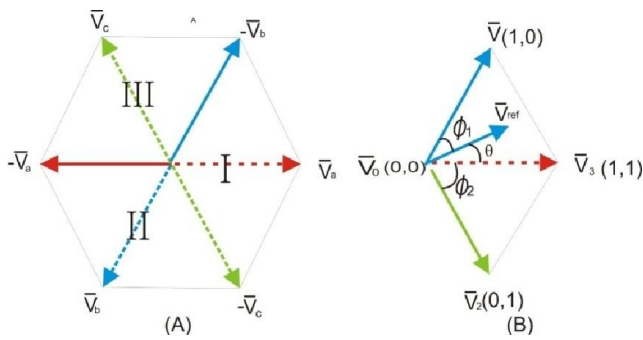

Fig. 4. Switching sequences a) sectors of operation b) sector I

**Simulation Model**

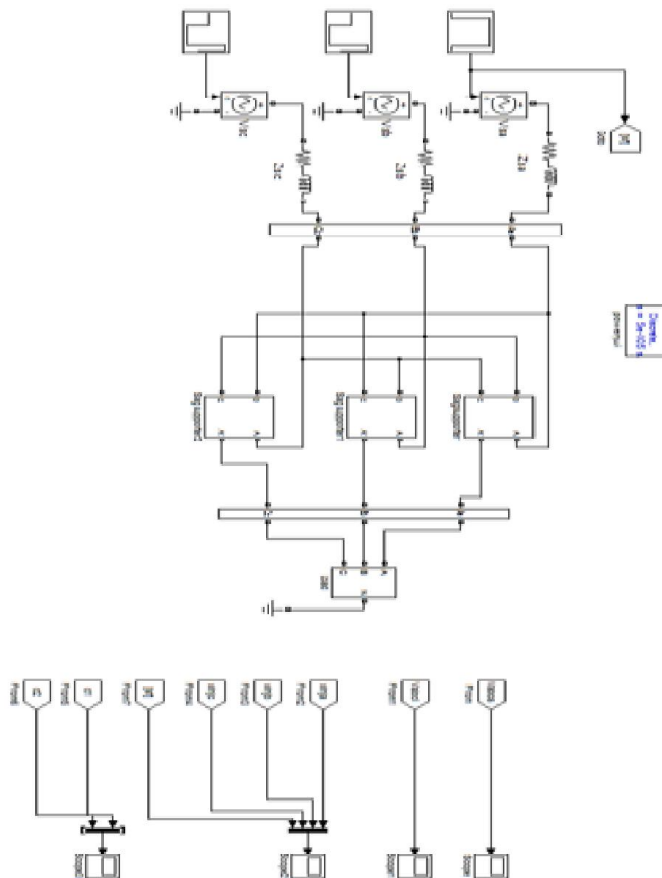
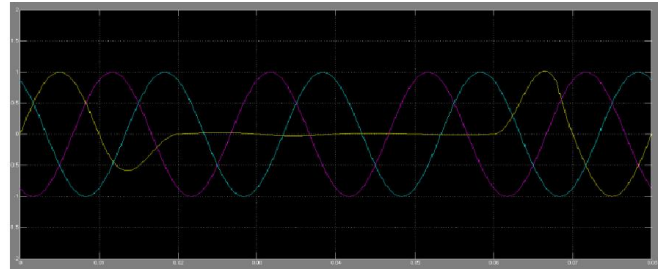

Fig. 5. Simulation model

**Experimental Results**

**Case a) compensation of sag type  $B_a$**



**Case b) Compensation of sag type  $B_a$  load voltage**

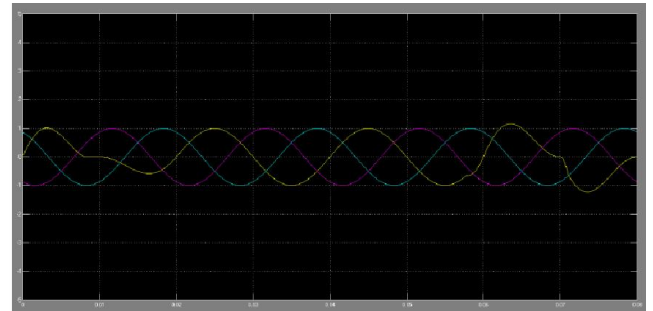

**Case c) Injected Voltages with Sag Flag**

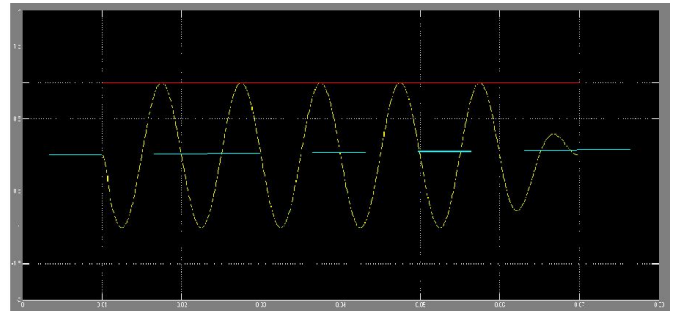

**Case d) Duty Cycle of the choppers in phase A sag Supporter**

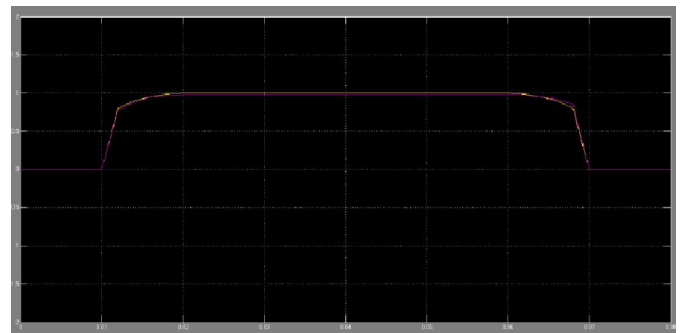

Similarly compensation can be carried for sag type  $C_a$  and sag type A.

**Conclusion**

A control scheme based on the characterization of voltage swell is proposed. It is tested on interphase ac-ac converter topology and it is found that the scheme besides compensation gives insight on the limits on compensation imposed by

various sag types. Therefore, it aids in the flexible compensation by switching between presag and inphase compensation. The scheme provides 100% compensation for type sag, and for all other types, compensation up to 50% sag magnitude with phase jumps ranging from 60 to 60 for interphase ac-ac topology. The algorithm takes, at most, half a cycle to compensate and it works in the presence of harmonics and unbalance, since the Fourier transform is employed to extract the fundamental component. Voltage sags have been mainly characterized by magnitude and duration. This paper presents a broad voltage swell, sag and other power system disturbances in terms of its magnitude, duration and phase-angle jump by using MATLAB/SIMULINK.

## REFERENCES

- Aeloíza, E. C., Enjeti, P. N., Morán, O. C. L. A., M. Hernandez, and S. Kim, 2003. "Analysis and design of a new voltage sag compensator for critical loads in electrical power distribution systems," *IEEE Trans. Ind. Appl.*, vol. 39, no. 4, pp. 1143–1150, Jul./Aug.
- Babaei, E., Kangarlu, M. F., and Sabahi, M. 2010. "Mitigation of voltage disturbances using dynamic voltage restorer based on direct converters," *IEEE Trans. Power Del.*, vol. 25, no. 4, pp. 2676–2683, Oct.
- Bollen M. H. J. 2000. *Understanding Power Quality Problems*. Piscataway, NJ, USA: IEEE.
- Dugan, R. C., McGranaghan, M. F., Santoso, S. and Beaty, H.W. 2004. *Electrical Power Systems Quality*. (New York, USA:McGraw-Hill).
- Garcia-Vite, P. M., David, F. M. and Ramirez, J.M. 2013. "Per-sequence vector-switching matrix converter modules for voltage regulation," *IEEE Trans. Ind. Electron.*, vol. 60, no. 12, pp. 5411–5421, Dec.
- Ghosh, A. and Ledwich, G. *Power Quality Enhancement Using Custom Power Devices*. Norwell, MA, USA
- Hietpas, S. M. and Naden, M. 2000. "Automatic voltage regulator using an AC voltage-voltage converter," *IEEE Trans. Ind. Appl.*, vol. 36, no. 1, pp. 33–38, Jan./Feb.
- Nielsen, J. G. and Blaabjerg, F. 2005. "A detailed comparison of system topologies for dynamic voltage restorers," *IEEE Trans. Ind. Appl.*, vol. 41, no. 5, pp. 1272–1280, Sep./Oct.
- Power Quality (R. S. Vedam and M. S. Sarma) *VAR Compensation in Power Systems*. Boca Raton (FL, USA: CRC, 2009).
- Prasai, A. and Divan, D. M. 2009. "Zero-energy sag corrector with reduced device count," *IEEE Trans. Power Electron.*, vol. 24, no. 6, pp. 1646–1653, Jun.
- Subramanian, S. and Mishra, M. K. 2010. "Interphase AC-AC topology for voltage sag supporter," *IEEE Trans. Power Electron.*, vol. 25, no. 2, pp. 514–518, Feb.
- Suma, J. and Mishra, M. K. 2013. "Instantaneous symmetrical component theory based algorithm for characterization of three phase distorted and unbalanced voltage sags," in *Proc. IEEE Int. Conf. Ind. Technol.*, Feb., pp. 845–850.
- Venkataramanan, G., Johnson, B. K. and A. Sundaram, 1996. "An AC-AC power converter for custom power applications," *IEEE Trans. Power Del.*, vol. 11, no. 3, pp. 1666–1671, Jul.
- Wang, B. and Venkataramanan, G. 2009. "Dynamic voltage restorer utilizing a matrix converter and flywheel energy storage," *IEEE Trans. Ind. Appl.*, vol. 45, no. 1, pp. 222–231, Jan./Feb.

\*\*\*\*\*