



ISSN: 0976-3376

Available Online at <http://www.journalajst.com>

ASIAN JOURNAL OF
SCIENCE AND TECHNOLOGY

Asian Journal of Science and Technology
Vol. 6, Issue 06, pp. 1533-1538, June, 2015

RESEARCH ARTICLE

MULTI-BAND HORN-SHAPE MONOPOLE PATCH ANTENNA FOR PERVASIVE COMMUNICATION

¹Jyoti Tagde and ²Prashant Yadav

NRI Institute of Research and Technology, Bhopal (M.P)-462021, India

ARTICLE INFO

Article History:

Received 27th March, 2015
Received in revised form
02nd April, 2015
Accepted 18th May, 2015
Published online 29th June, 2015

Key words:

Multiband,
FR4,
Teflon,
Monopole antenna.

ABSTRACT

This novel approach of multiband monopole antenna for ultra-wide band applications with triple and quad band-notched function has been proposed. The proposed design of a horn shape monopole patch antenna, which provides a wide usable fractional bandwidth of more than 88% (2-15GHz). Which covers WLAN, UWB (IEEE 802.15.3a, 3.1-10.6GHz) applications with a gain of 3.632dB at 10GHz frequency, and the return loss of -15.3782 dB, -13.0252 dB, -24.5378 dB and -20.5882dB. Bidirectional radiation patterns with a stable gains over the operating bands were obtained, which makes the antenna good for dual-band and multi-band wireless communication applications. The proposed antenna was fabricated with different dielectric material. The designed multi-band antenna has a substrate size of 20*30 mm² and covers the frequency bands at 2, 4, and 5.16-9.81GHz. Dual-band and triple-band antennas are simulated and good results were obtained. The substrate of measurement includes Flame Retardant 4 (FR4) epoxy with its relative permittivity of 4.4 and its height is 1.6mm.

Copyright © 2013 Jyoti Tagde and Prashant Yadav. This is an open access article distributed under the Creative Commons Attribution License, which permits unrestricted use, distribution, and reproduction in any medium, provided the original work is properly cited.

INTRODUCTION

The ultra-wideband (UWB) communication systems have received a great attention from wireless communication system (Ali Foudazi *et al.*, 2012). While providing a wideband characteristic over the whole operating band the one of most critical issue is compact antenna designing in wireless application (Raoul O. Ouedraogo, 2014 and Jyoti R. Panda *et al.*, 2010). The dual-band antennas for UWB and wireless communication have been presented for bandwidth enhancement (Nasser Ojaroudi and Mohammad Ojaroudi, 2013 and Puran Gour and Ravishankar Mishra, 2014). Recently for combining multiple communications standards in a single compact wireless system, the demand for antennas with multiband operation has increased (Mahmoud Niroo-Jazi, 2011). In addition, to satisfy the multiband operation requirements, this type of antenna must be of a simple construction to make it cost-effective, compact in size, and easily integrated within the front-end circuitry of a transceiver. For the multi band antenna prototypes, monopole antenna of various configurations have become most popular because they provide attractive antenna characteristics, i.e. low profile, light weight, low cost, versatile configuration for exciting dual or multi-resonance modes, and exhibiting wide impedance bandwidth with desirable radiation characteristics.

These properties achieved by employing various feeding techniques. However, these monopole antennas require a relatively large ground-plane structure that can be of various configurations typically in the shape of a square, rectangle, circle, or ellipse. Defected ground structure (DGS) (Li *et al.*, 2013 and Abd Aziz *et al.*, 2014) has also been investigated and found to reduce the antenna size as well as excite additional resonance modes. When a microstrip patch antenna is loaded with ring slots (Imran Hasan *et al.*, 2013) and narrow strips (Ali Foudazi *et al.*, 2012) it gives multi-band frequency antenna characteristics.

Design of proposed antenna

Micro-strip antennas are also referred to as patch antennas, which consists of a very thin metallic strip (patch) placed a small amount of wavelength above a ground plane, with different shapes such as square, rectangular, circular, elliptical, or any other configuration. There are number of substrates that are used for designing the micro-strip antennas, and their dielectric constants are vary in the range of $2.2 \leq \epsilon_r \leq 12$ (Balanis, 2005). The performance of good antenna is depending on its dielectric constant. The configuration of the proposed monopole patch antenna is shown in fig.1, it is fabricated with different dielectric material which consist a rectangular box called substrate which is made up of the low cost FR4-epoxy (Flame Retardant4) with height 1.6mm, outer cylinder and pin is made up of copper material and the outer portion of pin is made up of Teflon (tm) and their property are shown in Table 1.

*Corresponding author: Jyoti Tagde

NRI Institute of Research and Technology, Bhopal (M.P)-462021,
India

Table 1. Property of used different material

Material Used	Relative Permittivity ϵ_r	Dielectric Loss Tangent $\tan \delta$
FR4-epoxy	4.4	0.02
Teflon	2.1	0.001
Copper	1	0

This modified UWB monopole antenna is designed directly from the circular Patch UWB-Monopole antenna with some modifications in the patch shape (Ramu Pillalamarri *et al.*, 2012) as shown in Fig. 1. After doing an extensive simulation study, we have applied a meandering line (Nipont Tangthong and Virote Pirajnenchai, 2012) for patch antenna for enhancing gain (Lei Chen *et al.*, 2015). The patch has been reshaped from a circular to semi-circular to make the antenna compact (Mahmoud Niroo-Jazi, 2011 and Li *et al.*, 2013) and by adding a rectangle box for making a semicircle to horn shape. In order to realize the suitable ratio of the mode resonant frequencies we select the position and the size of shorting pin. Microstrip patch antenna is loaded with ring slots (Imran Hasan *et al.*, 2013) and narrow strips (Ali Foudazi *et al.*, 2012) it gives multi-band frequency antenna characteristics and a special advantage that it has simple structure, wider bandwidth, and less conductor loss.

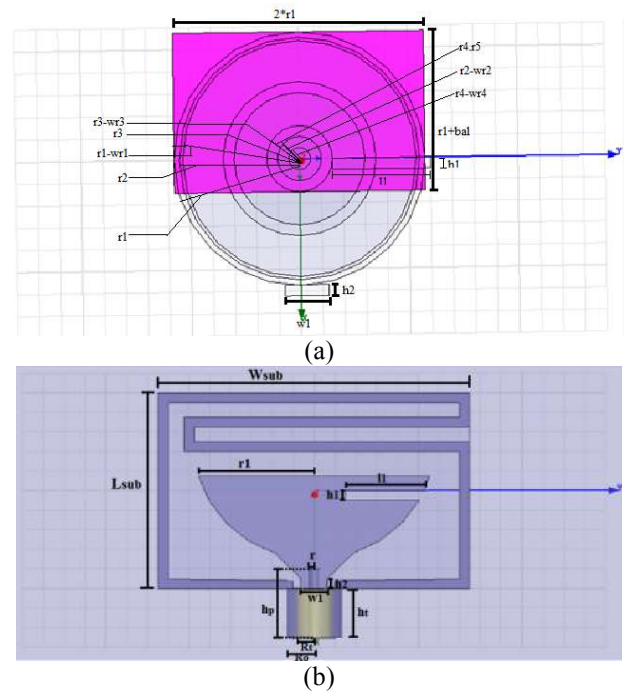

Fig.2(a) Excitation patch with different circular ring. (b) Dimensions of proposed antenna

The proposed antenna is connected with 50Ω connector for signal transmission. And apply a meander line for enhancing gain. The dimensions of proposed antenna are shown in Table 2. In the designing of basic micro-strip patch antenna (Balanis, 2005), the below equations (1) and (2) is used to calculate the dimensions of the radiating element in the patch designing.

$$\epsilon_{reff} = \frac{\epsilon_r + 1}{2} \tag{1}$$

The multi-band antenna is designed to create triple operating frequency bands in which the last band offers an ultra-wideband performance. The monopole antenna is designed for a resonant frequency $f_1=3\text{GHz}$, and for $f_2=9.68\text{GHz}$. The outer radius of circular patch is $r_1=11.5\text{mm}$. This values is calculated by using the following formula (Mahmoud Niroo-Jazi, 2011).

$$f_2 = \frac{cK}{2\pi r_1 \sqrt{\epsilon_{reff}}} \tag{2}$$

Where $K=3.832$

Normally, the micro-strip antenna is not having broader bandwidth because it has only one resonance. Thus for designing wideband antenna with two or more resonance frequency. It is required to overlapping these multiple resonances may lead to or wideband.

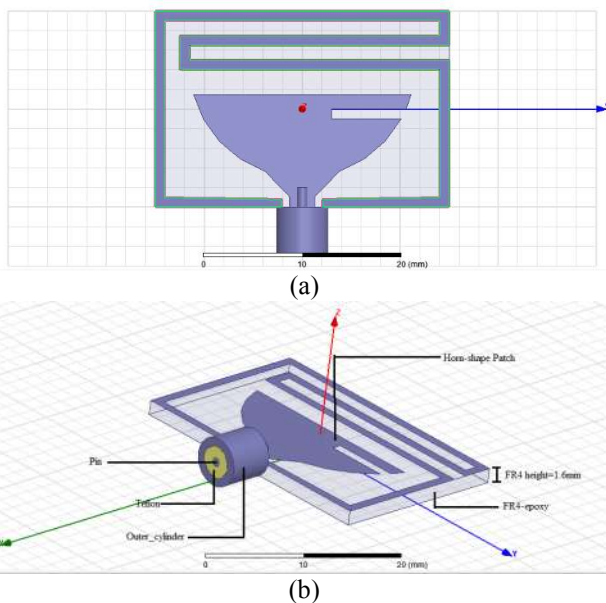

Fig.1 Geometry of proposed antenna. (a) Front view, (b) Side view

The Teflon is used in outer cylindrical portion of the pin shown with yellow colour in the above figure. The proposed antenna configuration consisting of a horn shape patch with small shorting pin and probe feeding line for an infinite ground plane.

Table 2. Dimensions of proposed antenna

Parameter	mm	Parameter	mm	Parameter	mm	Parameter	mm
Lsub	20	r5	3	wr2	9	h _t	5
Wsub	30	l1	-9	wr3	1	w1	-2.5
r1	11.5	h1	1	wr4	2	h2	-1
r2	11	r	0.5	wr5	2.9	bal	3
r3	7	h _p	-7	R _t	1.66	feed	1
r4	3	wr1	0.8	R _o	2.66	feed1	0

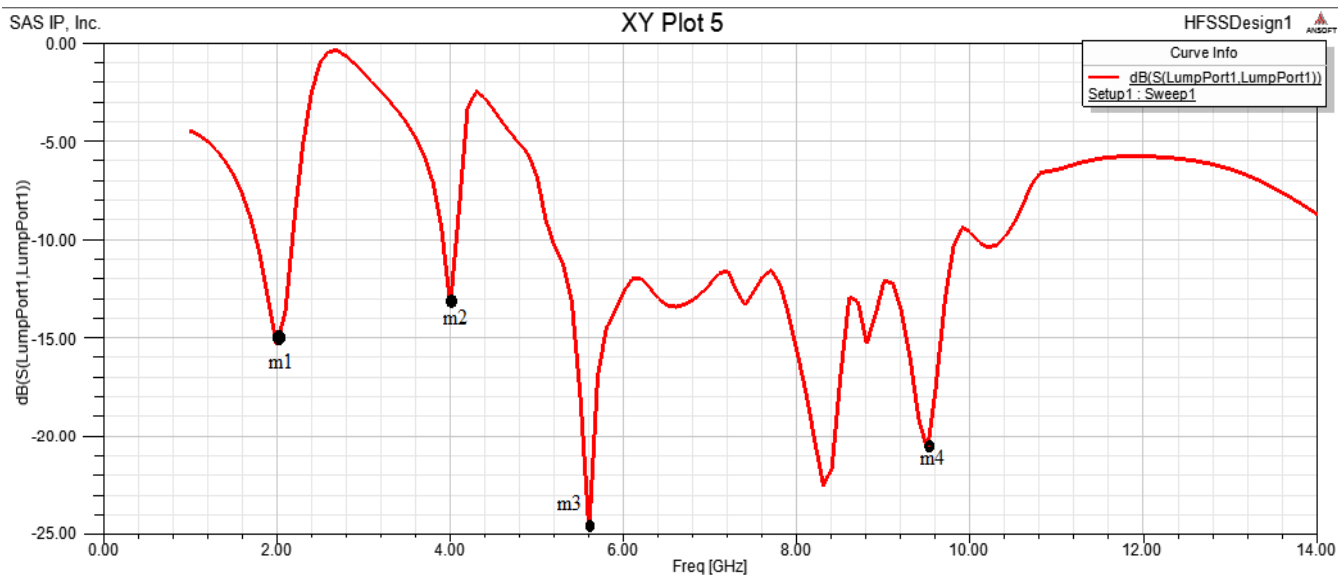

Fig.3. Simulation of Return Losses

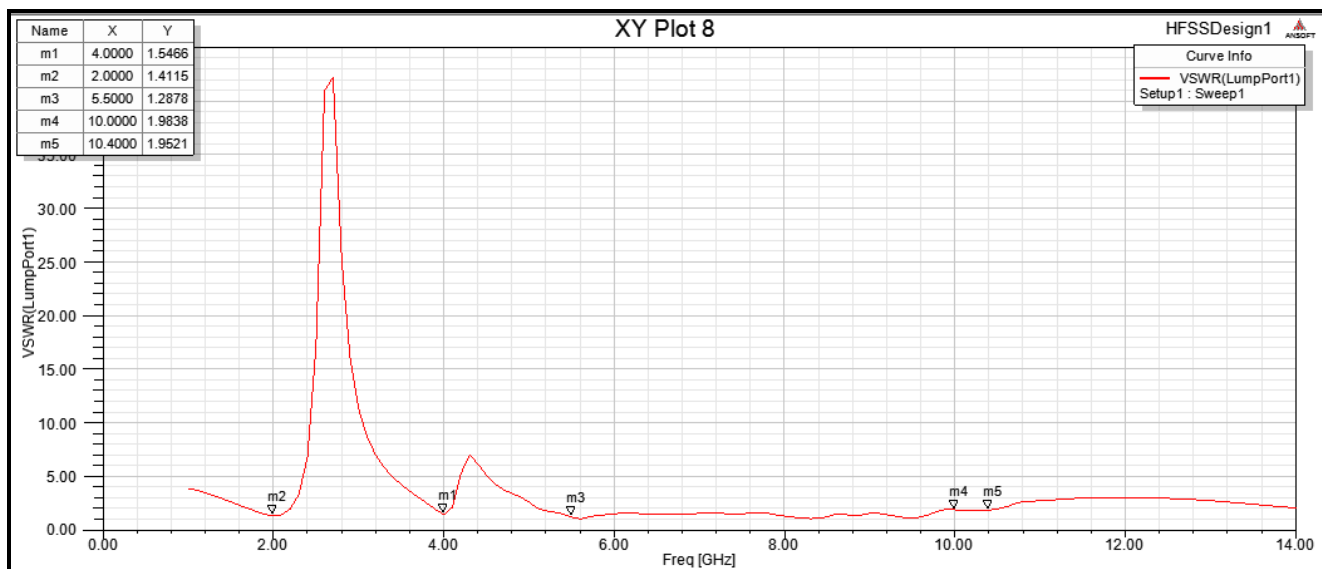

Fig.4. VSWR vs. Frequency of Proposed Antenna

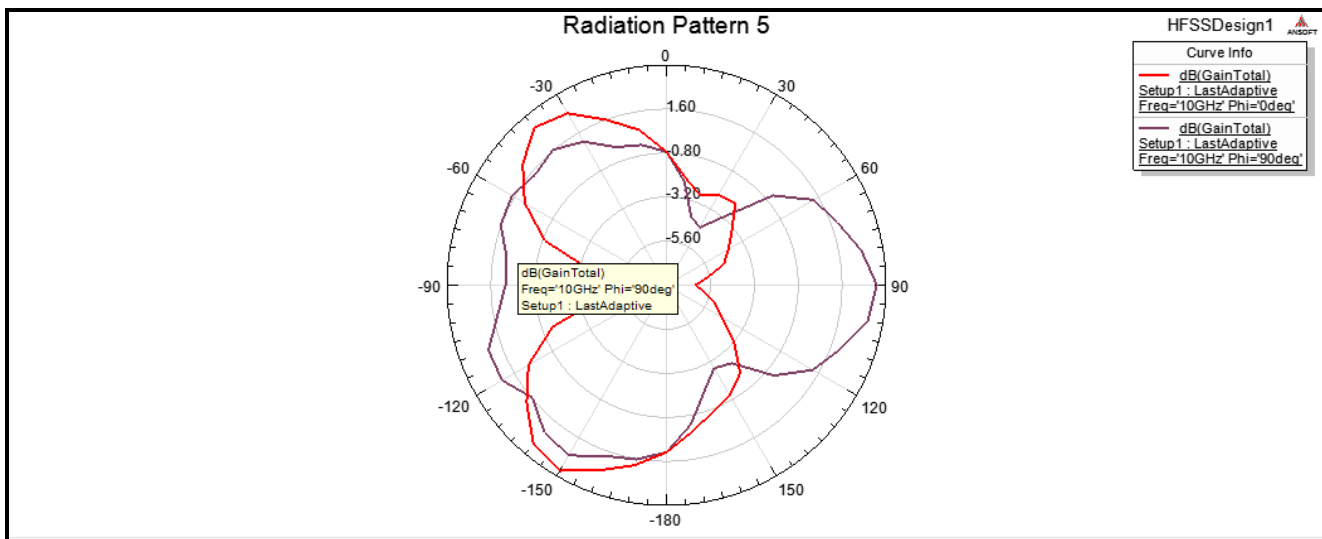

Fig.5. Radiation pattern of Gain total

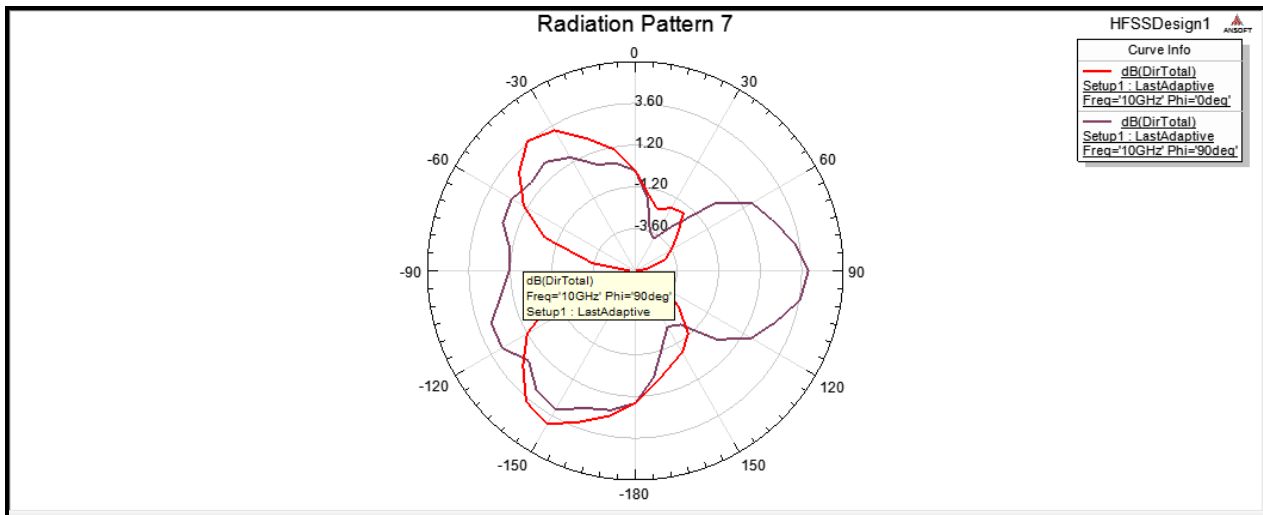

Fig.6. Radiation pattern of Directivity

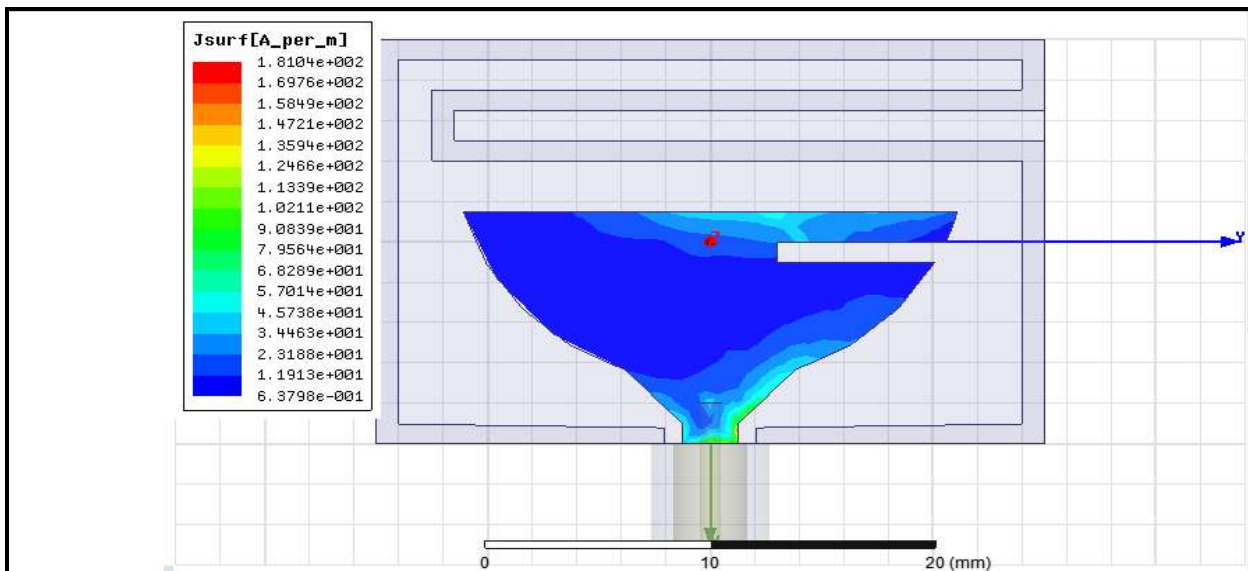

Fig.7 Current distribution of Antenna

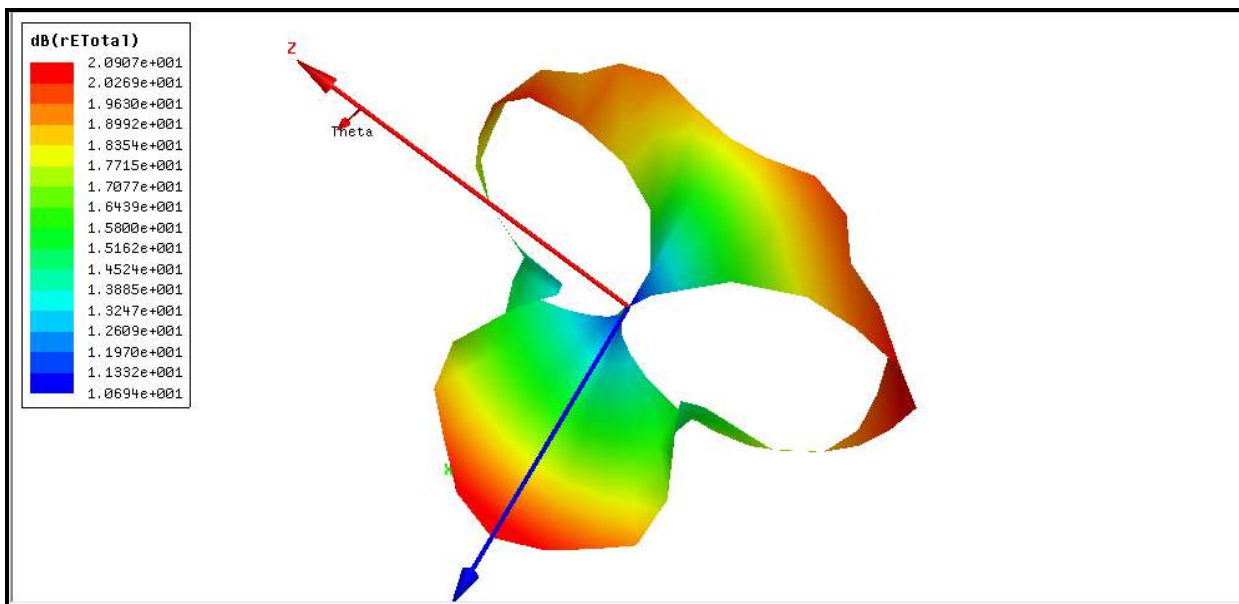

Fig.8. 3d Polar Plot

Therefore the proposed antenna is used to design to operate in two or more resonant bands for achieving UWB and the extra-band up to 15GHz.

Table 3. Simulation result of proposed antenna

Centre Frequency (GHz)	Return Loss (dB)	Bandwidth		Working Band
		(GHz)	(%)	
2	-15.3782	1.7463-2.1607	21.21	s-band
4	-13.0252	3.8922-4.0550	4.097	l-band
5.5793-9.4863	-24.5378 to -20.5882	5.1649-9.8118	62.05	c-band

The simulated return loss are obtained at -15.38dB,-13.02dB, -24.54dB and -20.58dB at 2GHz, 4GHz, 5.579GHz and 9.4863GHz respectively, therefore this band are applicable for s-band, l-band, c-band and x-band applications i.e. it is used for different pervasive communication applications.

$$BW_{\text{Broadband}} = \frac{f_H}{f_L}$$

$$BW_{\text{Narrowband}}(\%) = \frac{[f_H - f_L]}{f_C} \times 100$$

$$\text{Where } f_C = \frac{(f_H + f_L)}{2}$$

When the ratio of $f_H/f_L = 2$, the antenna is said to be broadband

RESULTS AND DISCUSSION

The proposed antenna is designed with An soft simulation software high frequency structure simulator (HFSS). In the Fig.3 shows that it designed quad-bands antenna and covers s-band of 1.73-2.16GHz centred at 2 GHz, C-band of 3.90-4.05GHz centred at 4GHz and it has a wider impedance bandwidth in the c-band and x-band from 5.16-9.81GHz centred at 5.5941 and 9.49GHz respectively. In addition the proposed antenna when compared to the references has the following advantages; it has high gain and significantly reduced dimensions.

In every curve its VSWR is shown less than 2.0, and from 5.50-10.40GHz it performs excellent impedance bandwidth for wireless communication applications. And it has fractional B.W of 61.63%.

It has gain of 2.88dB at 10GHz frequency and -160° theta from the radiation pattern the proposed antenna is bidirectional antenna. The maxima is occurs at elevation angle -30° to -150°.

The radiation pattern of this proposed antenna is bi-directional, and its directivity is 3.14dB at 10GHz and -160° theta.

Conclusion

A multi-band monopole antenna with simple structure for Wi-Fi, WLAN, and pervasive communication applications has been proposed and investigated in this research paper. With

the multi-band, the bandwidth is enhanced up to 88%.The gain is achieved with this antenna is 2.88dB and the directivity of this antenna is 3.14dB. The achieved results show that the antenna is working well in multi-band communication system. These antennas are small and scale down and their wide applications in the pervasive communication systems will be easier and more important. And their multiband application has advantage in performing different tasks in single antenna.

REFERENCES

- Ali Foudazi, Hamid Reza Hassani, and Sajad Mohammad alinezhad, 2012. "Small UWB Planar Monopole Antenna with Added GPS/GSM/WLAN Bands," *IEEE Transactions on Antennas and Propagation*, Vol. 60, No. 6, pp. 2987-2992.
- Raoul O. Ouedraogo, 2014. *Member, IEEE*, Junyan Tang, Student Member, *IEEE*, Kazuko Fuchi, Edward J. Rothwell, Fellow, *IEEE*, Alejandro R. Diaz, and PremChahal, Member, *IEEE*, "A Tunable Dual-Band Miniaturized Monopole Antenna for Compact Wireless Devices," *IEEE Antennas And Wireless Propagation Letters*, Vol. 13, pp. 1247-1250.
- Jyoti R. Panda, Aditya S. R. Saladi and Rakesh S. Kshetrimayum, 2010. "A Compact 3.4/5.5 GHz Dual Band-Notched UWB Monopole Antenna With Nested U-Shaped Slots," *Second International conference on Computing, Communication and Networking Technologies, IEEE*.
- Nasser Ojaroudi and Mohammad Ojaroudi, 2013. *Student Member, IEEE*, "Novel Design of Dual Band-Notched Monopole Antenna with Bandwidth Enhancement for UWB Applications," *IEEE Antennas and Wireless Propagation Letters*, Vol. 12, pp. 698-701.
- Mahmoud Niroo-Jazi, 2011. *Student Member, IEEE*, and Tayeb A. Denidni, Senior Member, *IEEE*, "A New Triple-Band Circular Ring Patch Antenna With Monopole-Like Radiation Pattern Using a Hybrid Technique," *IEEE Transactions On Antennas And Propagation*, Vol. 59, no. 10, pp. 3512-3517.
- Li.Li, Shu-hua. Rao, Bin. Tang and Ming-fu.Li, 2013. "A Novel Compact Dual-band Monopole Antenna using Defected Ground Structure," *International Workshop on Microwave and Millimeter Wave Circuits and System Technology, IEEE*.
- Abd Aziz, M. Z. A., B. I. Asadingo, H. Nornikman, M. H. Ramli, B. H. Ahmad, M. A. Othman, 2014. "Fork-Like Shaped Monopole Antenna with Defected Parasitic Elements and Ring Slots," *IEEE International Conference on Control System, Computing and Engineering*, 28 - 30, Penang, Malaysia.
- Balanis, C. A. 2005. *Antenna Theory*, 3rd ed. Hoboken, NJ, USA: Wiley.
- Nipont Tangthong and Virote Pirajnenchai, 2012. "A Dual Wideband CPW-Fed Plannar Monopole Antenna with Single Band Notched using Meandered Line," *IEEE*.
- Lei Chen, Zhenya Lei and Xiaowei Shi, 2015. "Meander-Line Based Broadband Artificial Material for Enhancing the Gain of Printed End-Fire Antenna," *Progress In Electromagnetics Research*, Vol. 151, 55-63.
- PuranGour and Ravishankar Mishra, 2014. "Bandwidth Enhancement of a Backfire Microstrip Patch Antenna for

- Pervasive Communication,” *International Journal of Antennas and Propagation*, Vol.
- TakJinpil, Hong Youngtaek and Choi Jaehoon, 2014. “A Cylindrical Monopole Antenna with A Higher Order Mode Ring Patch for Wideband Applications,” *IEEE* pp. 481-484.
- Vijay K. Sambhe, R. N. Awale and AbhayWagh, 2012. “Ultra Wide Band Circular Ring Patch With Open Ended Slot And Rectangular Ground Planer Monopole Antenna,” *IET journal* pp. 452-457.
- RamuPillalamarri, G. SasiBhushanaRao and S. Srinivasa Kumar, 2012. “Semi- circular microstrip line fed printed monopole antennas for UWB communication,” *ACTA Technicacorviniensis- Bulletin of Engineering*, tome, pp. 71-74, Fascicule (Oct.-Dec.).
- Md. Imran Hasan, M.A. Motin and Md. Samiul Habib, 2013. “Circular ring slotting technique of making compact microstrip rectangular patch antenna for four band applications,” *IEEE*.
